



Subaru Crosstrek 2016-2017, XV Crosstrek 2015 Forester 2016-2018, Impreza 2015-2016 WRX, WRX STI 2016-2021

Visit MetraOnline.com for more detailed information about the product and up-to-date vehicle specific applications

KIT FEATURES

- ISO DDIN radio provision
- Painted two-tone silver and gloss black

KIT COMPONENTS

- A) Radio trim panel • B) Radio brackets • C) Metal speed clips (2) • D) (2) #10 x 3/4" Phillips screws

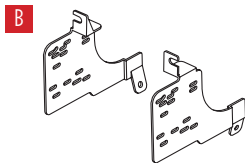
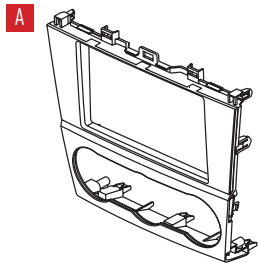

TABLE OF CONTENTS

Dash Disassembly	2-5
Kit Assembly	6

WIRING & ANTENNA CONNECTIONS (sold separately)

- Wiring Harness: 70-1761
- Antenna Adapter: 40-LX11

TOOLS REQUIRED

- Panel removal tool • Phillips screwdriver
- 10 mm socket wrench and long extension

Attention! With the key out of the ignition, disconnect the negative battery terminal before installing this product. Ensure that all installation connections are secure before cycling the ignition to test this product.

DASH DISASSEMBLY

1. Unsnap and remove the outside trim panel from the driver's side dash. (Figure A)
2. Remove (2) Phillips screws from the driver knee trim panel and remove the panel. (Figure B)
3. Remove (2) 10 mm nuts now exposed and lower the driver airbag assembly (no need to disconnect). (Figure C)

Continued on next page

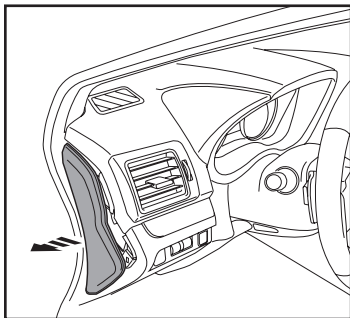

(Figure A)

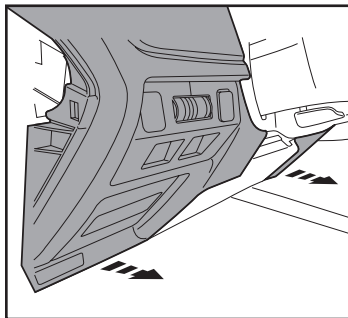

(Figure B)

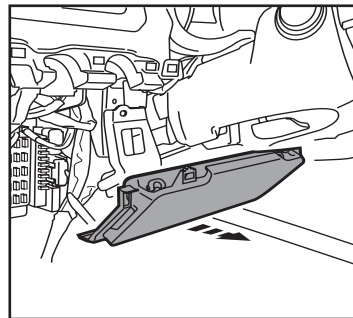

(Figure C)

DASH DISASSEMBY (CONT.)

4. Release the glove box retaining cable, squeeze the sides and lower the glove box. (Figure D)
5. On both sides unclip and remove the climate control cables, accessed under the dash on the driver side and through the glove compartment opening on the passenger side. (Be sure to watch where the cables are routed). Note, this step is not necessary in vehicles with automatic climate controls. (Figure E, F)

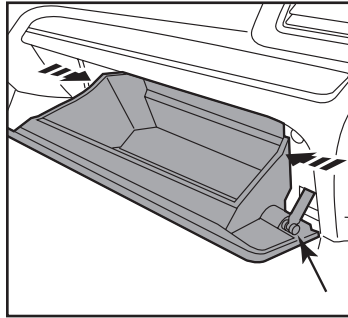

(Figure D)

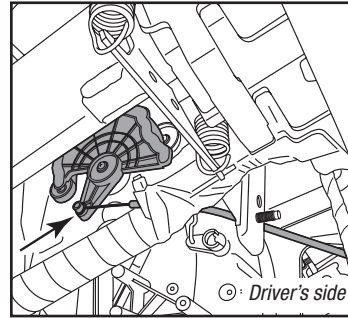

(Figure E)

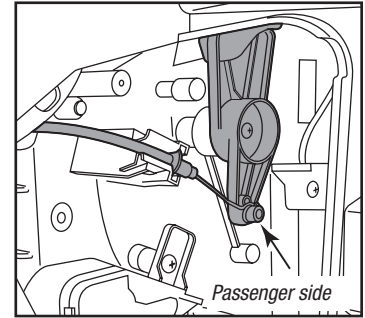

(Figure F)

Continued on next page

DASH DISASSEMBLY (CONT.)

- Remove (1) 10 mm bolt from lower radio supports on each side of the dash (these will be near where the climate control cables were removed, a long extension will be necessary to reach them). (Figure G, H)
- Unsnap the vent assembly above the radio and unplug the hazard button. (Figure I)

Continued on next page

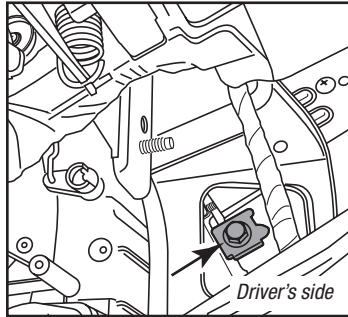

(Figure G)

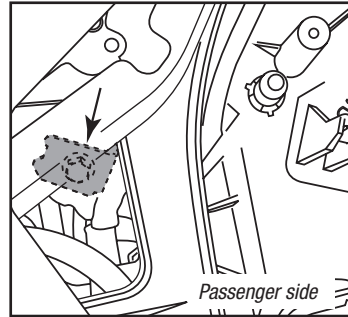

(Figure H)

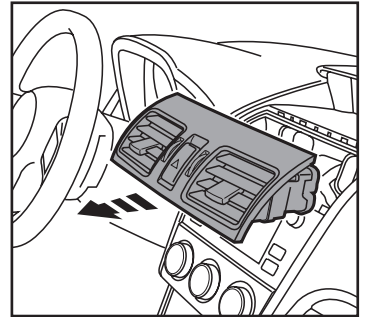

(Figure I)

DASH DISASSEMBLY (CONT.)

8. Remove (2) 10 mm bolts from the top radio mounts. (Figure J)
9. Remove and unplug the radio from the dash.
10. Unscrew the radio brackets and remove the factory climate controls from the radio trim. (Figure K)

Continue to kit assembly

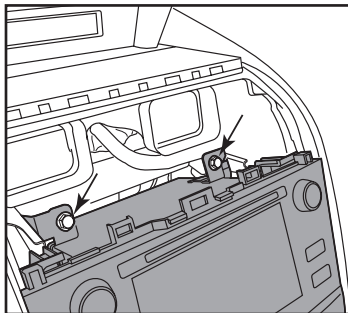

(Figure J)

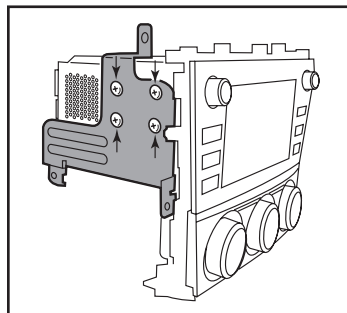

(Figure K)

KIT ASSEMBLY

1. Attach the factory climate controls to the new **radio trim panel** using the factory hardware.
2. Slide the (2) provided **speed clips** onto the lower factory mounting brackets. (Figure A)
3. Attach the **radio brackets** to the radio using the screws supplied with the radio. (Figure B)
4. Locate the factory wiring harness and antenna connector in the dash, and complete all necessary connections to the radio. Metra recommends using the proper mating adapter from Metra and/or AXXESS. Re-connect the negative battery terminal and test the radio for proper operation.

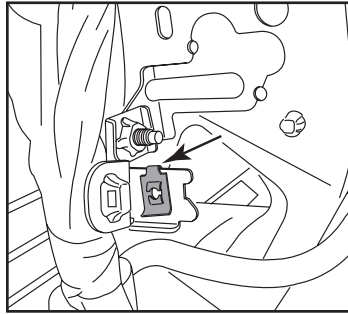

(Figure A)

5. Mount the radio into the dash cavity using the factory 10 mm bolts on the top mounts and (2) supplied #10 x 3/4" Phillips screws on the lower mounting points where the speed clips were previously attached.
6. Snap the **radio trim panel** over the radio and reassemble the dash in reverse order of disassembly.

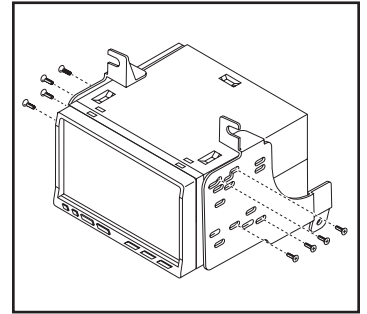

(Figure B)



95-8907HG
INSTALLATION INSTRUCTIONS



Having difficulties? We're here to help.



Contact our Tech Support line at:

386-257-1187



Or via email at:

techsupport@metra-autosound.com

Tech Support Hours (Eastern Standard Time)

Monday - Friday: 9:00 AM - 7:00 PM

Saturday: 10:00 AM - 7:00 PM

Sunday: 10:00 AM - 4:00 PM



KNOWLEDGE IS POWER

Enhance your installation and fabrication skills by enrolling in the most recognized and respected mobile electronics school in our industry. Log onto www.installerinstitute.edu or call 386-672-5771 for more information and take steps toward a better tomorrow.



**Metra recommends MECP
certified technicians**



Subaru

Crosstrek 2016-2017, XV Crosstrek 2015 Forester 2016-2018, Impreza 2015-2016 WRX, WRX STI 2016-2021

Visite MetraOnline.com para más información acerca del producto y las aplicaciones específicas más actualizadas del vehículo

CARACTERÍSTICAS DEL KIT

- Provisión de radio ISO DDIN
- Pintura en dos tonos, plateada y negra de alto brillo

COMPONENTES DEL KIT

- A) Panel de la moldura del radio • B) Soportes del radio • C) (2) ganchos para panel • D) (2) tornillos Phillips #10 de 3/4"

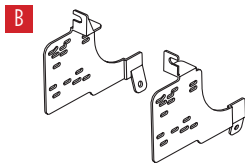
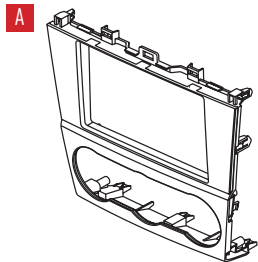

INDICE

Desmontaje del tablero	2-5
Ensamble del kit	6

CABLEADO Y CONEXIONES DE ANTENA

(se venden por separado)

- Arnés de cableado: 70-1761
- Adaptador de antena: 40-LX11

HERRAMIENTAS NECESARIAS

- Herramienta para quitar paneles
- Destornillador Phillips
- Llave de tubo de 10mm y extensión larga

¡Atención! Con la llave fuera del encendido, desconecte el terminal negativo de la batería antes de instalar este producto. Asegúrese de que todas las conexiones de la instalación estén seguras antes de encender y apagar el encendido para probar este producto.

DESMONTAJE DEL TABLERO

1. Suelte a presión y quite el panel de la moldura exterior del tablero del lado del conductor. (Figura A)
2. Quite los (2) tornillos Phillips del panel de la moldura junto a la rodilla del conductor y quite el panel. (Figura B)
3. Quite los (2) pernos de 10mm que están expuestos y baje el ensamble de la bolsa de aire del conductor (no es necesario desconectar). (Figura C)

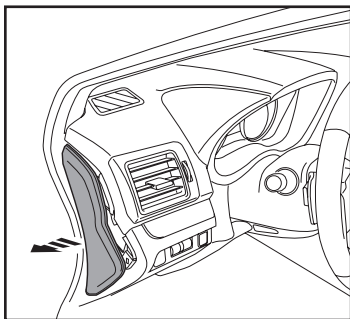

(Figura A)

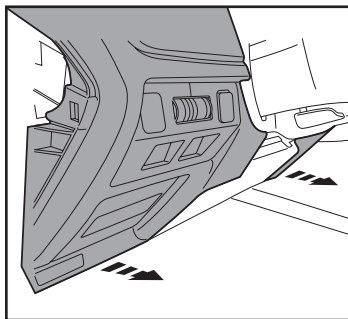

(Figura B)

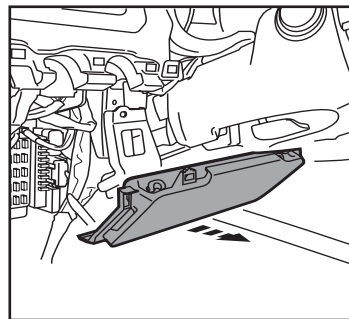

(Figura C)

Continúa en la siguiente página

DESMONTAJE DEL TABLERO (CONT.)

4. Suelte el cable de retención de la guantera, apriete los lados y baje la guantera. (Figura D)
5. En ambos lados desenganche y quite los cables del control de clima, accesibles debajo del tablero del lado del conductor y a través de la apertura de la guantera del lado del pasajero. (Asegúrese de observar por dónde van los cables). Tenga en cuenta que este paso no es necesario en vehículos con controles del clima automáticos. (Figura E, F)

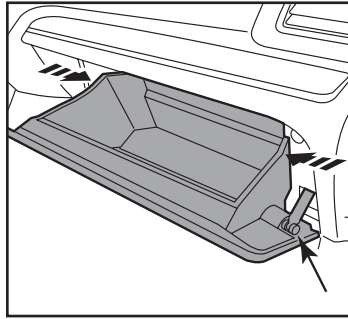

(Figura D)

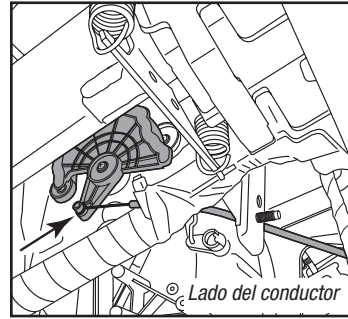

(Figura E)

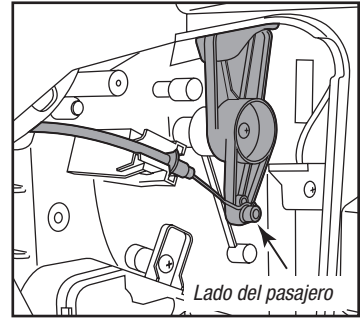

(Figura F)

Continúa en la siguiente página

DESMONTAJE DEL TABLERO (CONT.)

- Remove (1) 10 mm bolt from lower radio supports on each side of the dash (these will be near where the climate control cables were removed, a long extension will be necessary to reach them). (Figure G, H)
- Unsnap the vent assembly above the radio and unplug the hazard button. (Figure I)

Continued on next page

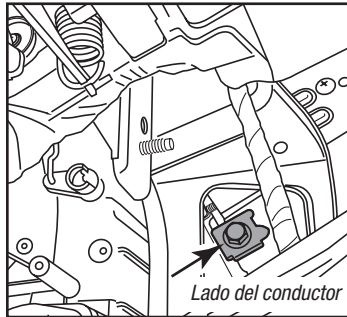

(Figura G)

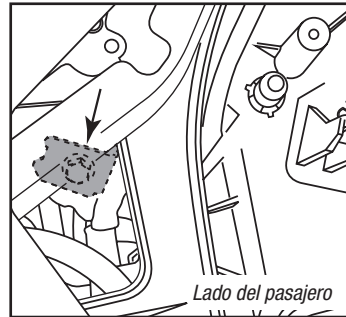

(Figura H)

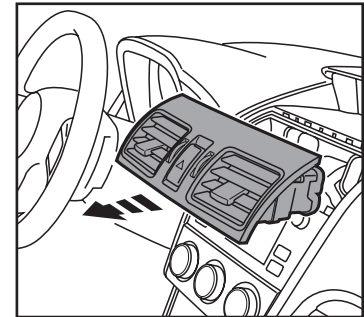

(Figura I)

DESMONTAJE DEL TABLERO (CONT.)

8. Quite los (2) pernos de 10mm que sujetan los montajes superiores del radio. (Figura J)
9. Quite y desconecte el radio del tablero.
10. Desatornille los soportes del radio y quite los controles del clima de fábrica de la moldura del radio. (Figura K)

Continúe con el ensamble del kit.

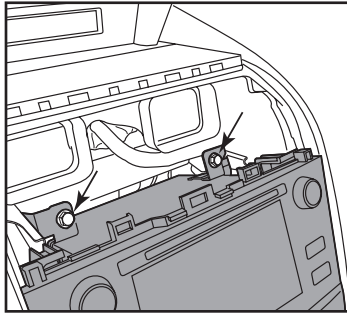

(Figura J)

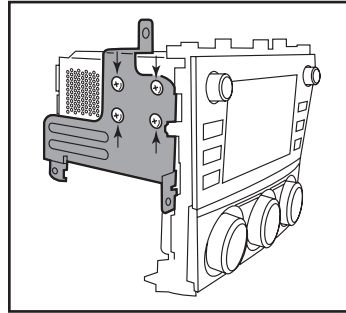

(Figura K)

ENSAMBLE DEL KIT

1. Sujete los controles del clima a la **moldura del nuevo radio** usando la tornillería de fábrica.
2. Deslice los (2) **ganchos** de seguridad suministrados en los soportes de montaje de fábrica inferiores. (Figura A)
3. Una los **soportes** al radio usando los tornillos que vienen con el radio. (Figura B)
4. Localice el arnés de cableado de fábrica y el conector de la antena en el tablero y realice todas las conexiones necesarias al radio. Metra recomienda el uso de adaptadores adecuados de acoplamiento de Metra y/o de AXXESS. Vuelva a conectar la terminal negativa de la batería y pruebe el radio para verificar que funcione correctamente.

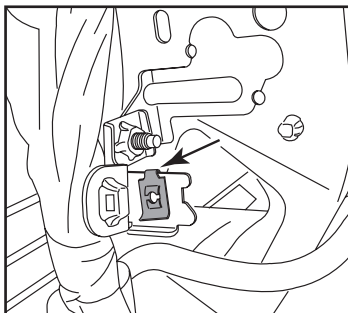

(Figura A)

5. Monte el radio en la cavidad del tablero con los pernos de 10 mm de fábrica de los montajes superiores y los (2) tornillos Phillips #10 de 3/4" en los puntos de montaje inferiores donde se sujetaron previamente los ganchos de seguridad.
6. Ponga a presión el **panel de la moldura del radio** sobre el radio y vuelva a armar el tablero al revés de como lo desarmó. Una los soportes al radio usando los tornillos que vienen con el radio.

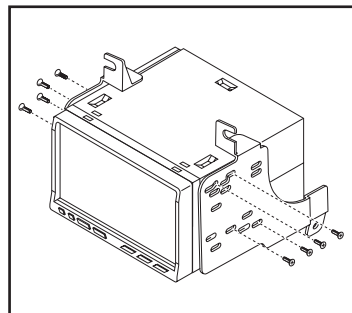

(Figura B)



95-8907HG
INSTRUCCIONES DE INSTALACIÓN



¿Tienes dificultades? Estamos aquí para ayudar.



Póngase en contacto con nuestra
línea de soporte técnico en:
386-257-1187



O por correo electrónico a:
techsupport@metra-autosound.com

Horas de soporte técnico (hora estándar del este)

Monday - Friday: 9:00 AM - 7:00 PM

Saturday: 10:00 AM - 7:00 PM

Sunday: 10:00 AM - 4:00 PM



KNOWLEDGE IS POWER

Enhance your installation and fabrication skills by enrolling in the most recognized and respected mobile electronics school in our industry. Log onto www.installerinstitute.edu or call 386-672-5771 for more information and take steps toward a better tomorrow.



**Metra recomienda MECP
técnicos certificados**