



INSTALLATION INSTRUCTIONS FOR PART 95-7344

APPLICATIONS

Kia Sportage 2011-up

95-7344G

95-7344CH

KIT FEATURES

- Double DIN head unit provision
- Painted Gray or Charcoal to match factory finish
G=Gray, CH=Charcoal



KIT COMPONENTS

- A) Radio Housing Trim Panel
- B) DDIN Radio Housing Brackets
- C) (4) Panel Clips

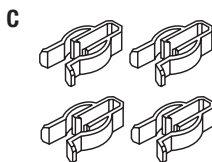
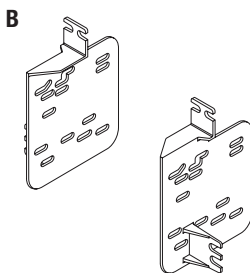
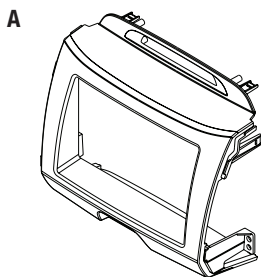

WIRING & ANTENNA CONNECTIONS (Sold Separately)

Wiring Harness:

- 70-7304 Hyundai Kia harness 2010-up

Antenna Adapter:

- Not Required

TOOLS REQUIRED

Panel Removal Tool • Phillips Screwdriver



METRA. THE WORLD'S BEST KITS.™



1-800-221-0932



metraonline.com

© COPYRIGHT 2004-2011 METRA ELECTRONICS CORPORATION



95-7344

Table of Contents

Dash Disassembly

– Kia Sportage 2011-up..... 3-4

Kit Preparation

– Kia Sportage 2011-up..... 5

Kit Assembly

– Double DIN head unit provision 6

Caution

Metra recommends disconnecting the negative battery terminal before beginning any installation. All accessories, switches, and especially air bag indicator lights must be plugged in before reconnecting the battery or cycling the ignition.

**NOTE: Refer also to the instructions included with the aftermarket radio.*



KNOWLEDGE IS POWER

Enhance your installation and fabrication skills by enrolling in the most recognized and respected mobile electronics school in our industry. Log onto www.installerinstitute.com or call 800-354-6782 for more information and take steps toward a better tomorrow.



Metra recommends MECP certified technicians

Dash Disassembly

1. Remove the screw in the instrument panel to the right of the “engine start” button then unclip the top panel of the steering column then unclip and remove the instrument panel. (Figure A)
2. Remove the screw in the dash panel above the glove box to the right of the radio then unclip and remove the dash panel. (Figure B)
3. Remove the two screws from the front of the radio panel, unclip and remove. (Figure C)

Continued on next page

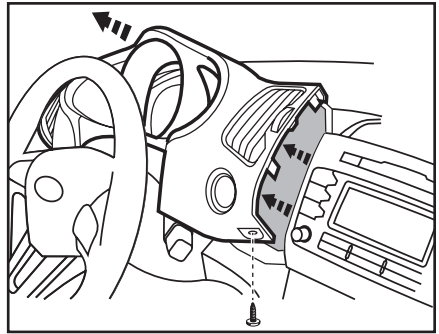

(Figure A)

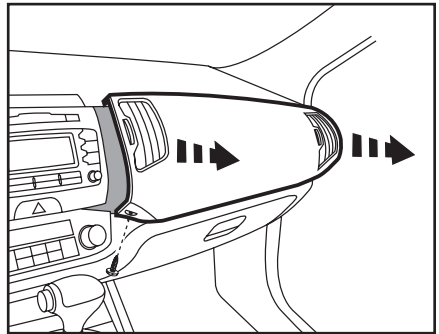

(Figure B)

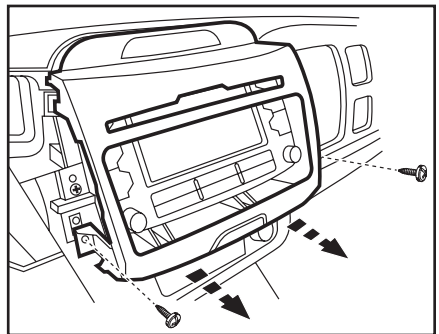

(Figure C)

Dash Disassembly

4. Unscrew the 4 Phillips screws securing the radio into the dash, unplug and remove the radio. (Figure D)
5. Remove the four screws securing the display into the factory panel and unclip the hazard button. Both items will need to be installed into the 95-7344 kit panel. (Figure E)

Continue to kit preparation

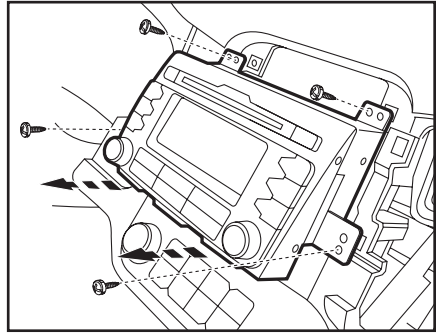

(Figure D)

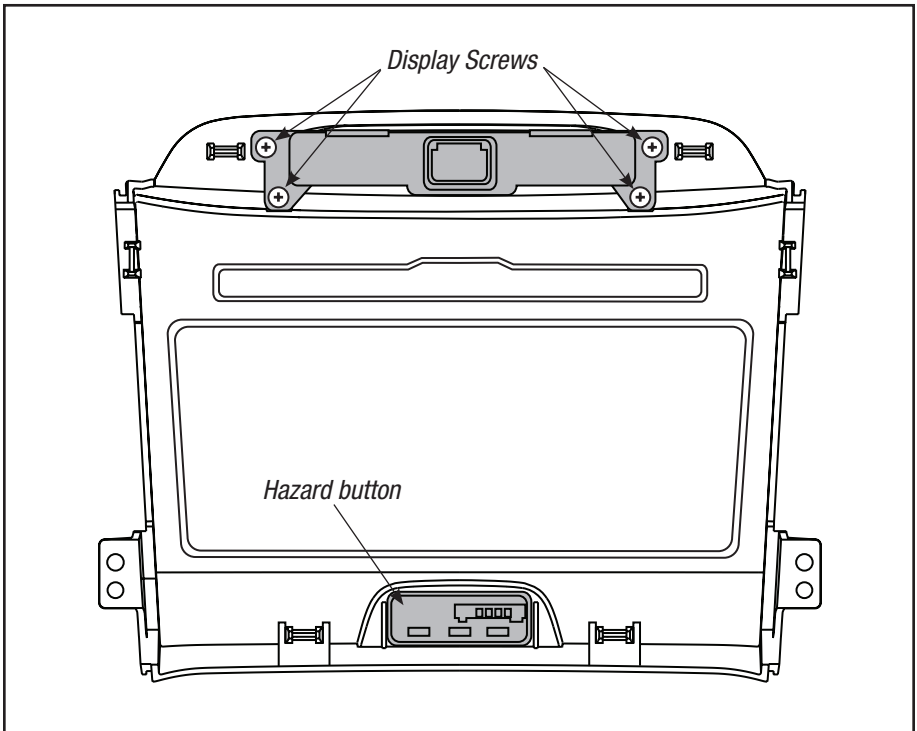

(Figure E)

Kit Preparation

1. Install the hazard button and display previously removed from the factory radio panel. (Figure A)
2. Attach the four included panel clips to the radio panel. (Figure A)

Continue to kit assembly

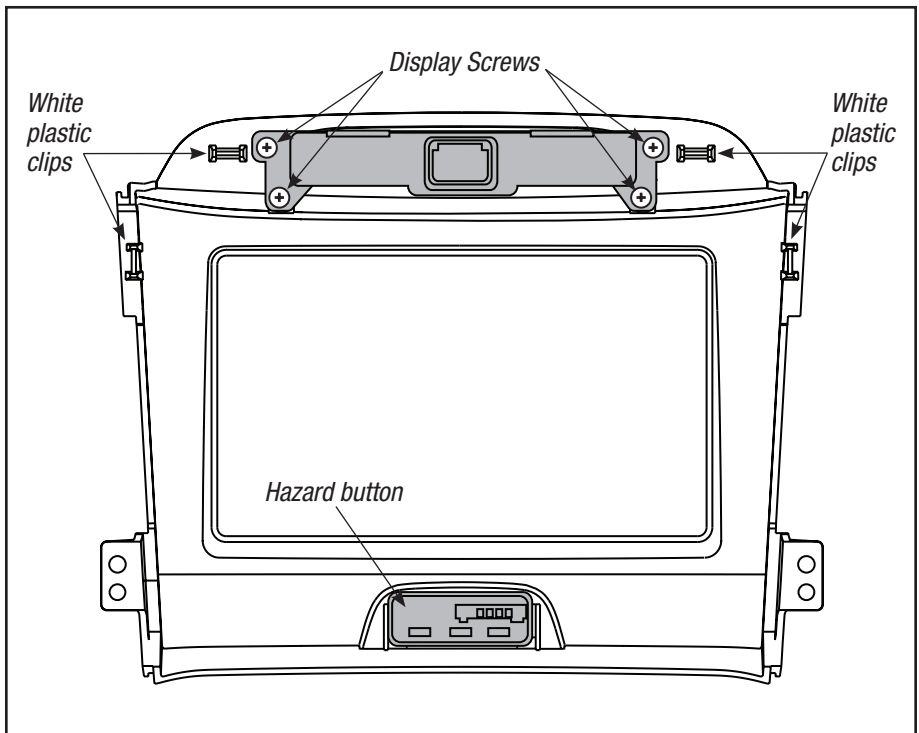

(Figure A)



Kit Assembly 95-7344

Double DIN head unit provision

1. Locate the factory wiring harness in the dash. Metra recommends using the proper mating adapter from Metra or AXXESS. Re-connect the negative battery terminal and test the unit for proper operation.
2. Mount the radio to the DDIN brackets using the screws supplied with the radio. (Figure A)
3. Mount the radio/bracket assembly into the dash. (Figure C)
4. Snap the radio trim plate over the radio/bracket assembly and reassemble dash in reverse order of disassembly. (Figure C)

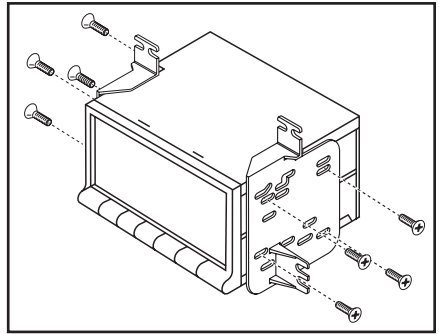

(Figure A)

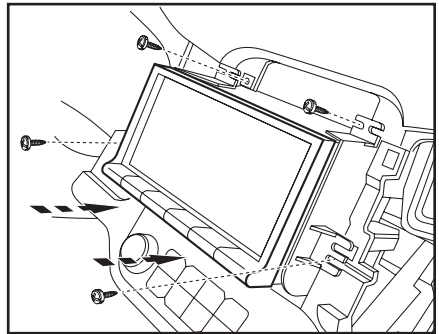

(Figure B)

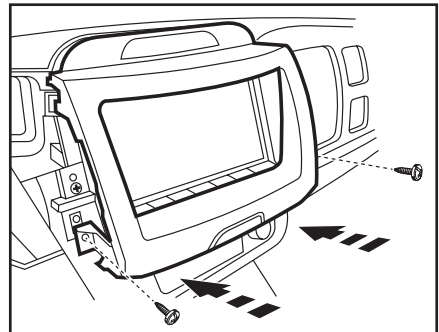

(Figure C)



INSTALLATION INSTRUCTIONS FOR PART 95-7344

REV. 6/08/11

METRA. THE WORLD'S BEST KITS.™



1-800-221-0932



metraonline.com

© COPYRIGHT 2004-2011 METRA ELECTRONICS CORPORATION