



Chrysler 200 LX (with 3.0" screen) **2015-Up**
 Jeep Cherokee Sport **2014-Up**
 Ram Trucks (without 8.4" touchscreen) **2013-2018**
 Ram Classic Trucks (without 8.4" touchscreen) **2019-Up**

Visit MetraOnline.com for more detailed information about the product and up-to-date vehicle specific applications

KIT FEATURES

- ISO DDIN radio provision
- Painted matte black
- **Note:** Modifications to the factory radio cavity is required

KIT COMPONENTS

- A) Radio housing • B) Brackets

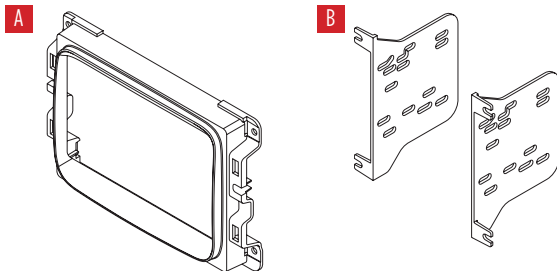

TABLE OF CONTENTS

Dash Disassembly

- Chrysler 200 LX (with 3.0" screen) 2015-Up.....2
- Jeep Cherokee Sport 2014-Up.....3-4
- Ram Trucks (without 8.4" touchscreen) 2013-2018.....5
- Ram Classic Trucks (without 8.4" touchscreen) 2019-Up ..5
- Kit Assembly6

WIRING & ANTENNA CONNECTIONS (sold separately)

Wiring Harness: Visit metraonline.com for audio/video and steering wheel control interface options.
 Antenna Adapter: 40-EU55

TOOLS REQUIRED

- Panel removal tool • Phillips screwdriver
- 9/32" socket wrench

Attention! With the key out of the ignition, disconnect the negative battery terminal before installing this product. Ensure that all installation connections are secure before cycling the ignition to test this product.

DASH DISASSEMBLY

Chrysler 200 LX (with a 3.0" screen) 2015-up

1. Unclip the radio trim bezel from the vehicle. (Figure A)
2. Remove (4) screws securing the radio to the dash, disconnect the connectors attached, and then remove the radio.

Continue to kit assembly

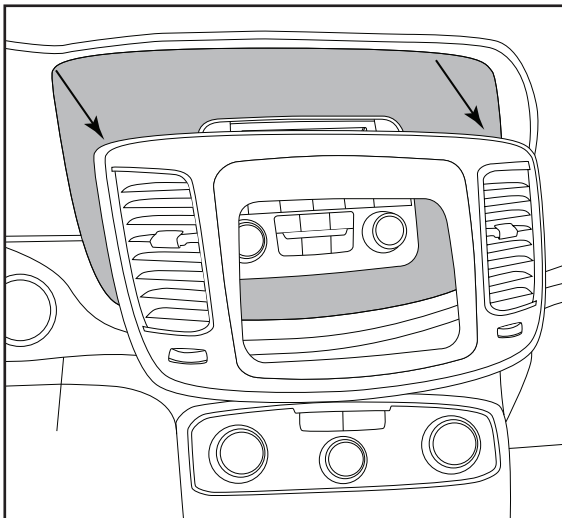

(Figure A)

DASH DISASSEMBLY (CONT.)

Jeep Cherokee Sport 2014-up

1. Unclip and remove the climate control panel from the vehicle and put to the side. (Figure A)
2. Remove (2) screws securing the radio trim bezel to the dash. (Figure B)
3. Unclip the radio trim bezel from the vehicle. (Figure C)
4. Remove (4) screws securing the radio to the dash, disconnect the connectors attached, and then remove the radio.

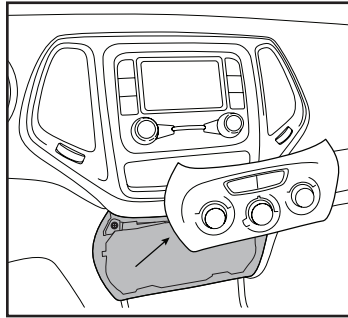

(Figure A)

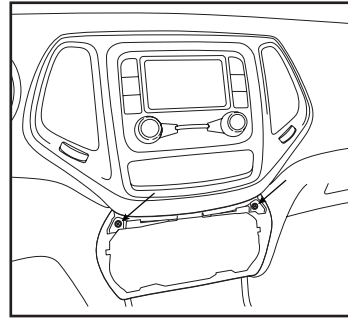

(Figure B)

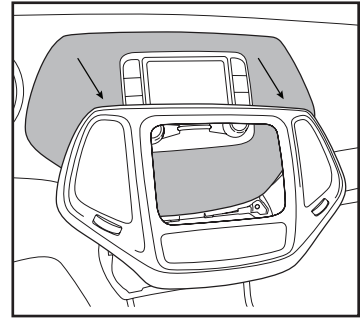

(Figure C)

Continued on the next page

DASH DISASSEMBLY (CONT.)

Jeep Cherokee Sport 2014-up

Sub-dash modification:

1. Remove the rubber cover from inside the pocket on top of the dash, and then remove (1) screw exposed.
2. Remove (2) screws below the radio cavity. (Figure A)
3. From inside the radio cavity, remove (2) screws securing the metal, radio sub-dash bracket, and then discard. (Figure B)
4. Carefully cut the plastic from the bottom rear portion of the radio cavity, down to the metal brace. (Figure C)

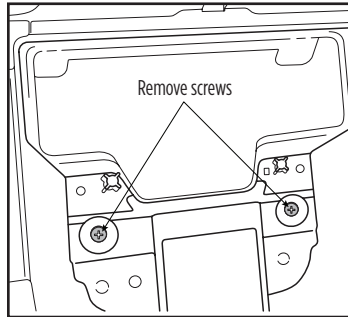

(Figure A)

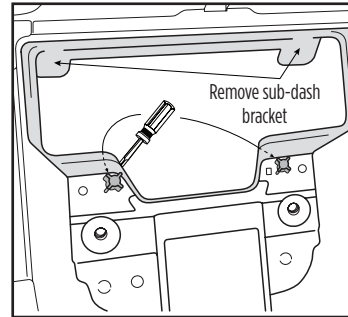

(Figure B)

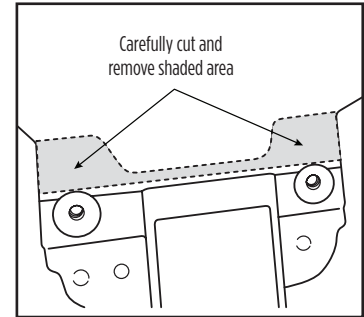

(Figure C)

Continue to kit assembly

DASH DISASSEMBLY

**Ram Trucks (without 8.4" touchscreen)
2013-2018**

**Ram Classic Trucks (without 8.4"
touchscreen) 2019-Up**

1. Remove liner inside tray at the top center of the dash and remove (2) torx screws. (Figure A)
2. Unsnap and remove radio panel. (Figure B)

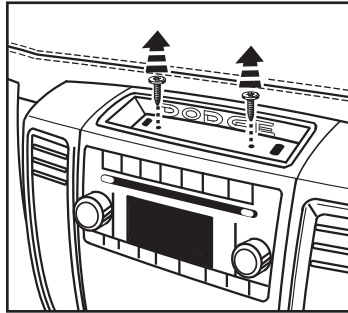

(Figure A)

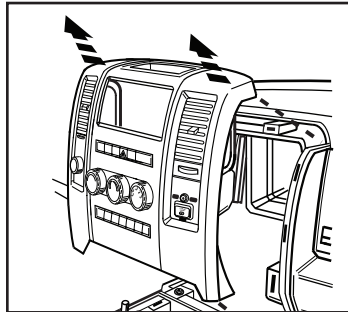

(Figure B)

3. Remove four screws and remove radio. (Figure C)
4. The factory rear support will need to be cut or removed to allow space for a new radio. The bottom section can be removed with two cuts at the bottom corners. (Figure D)

Continue to kit assembly

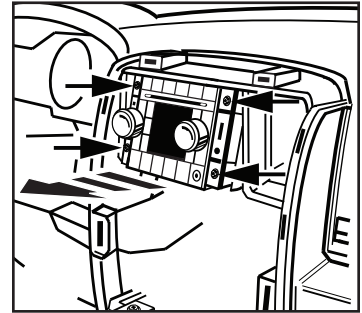

(Figure C)

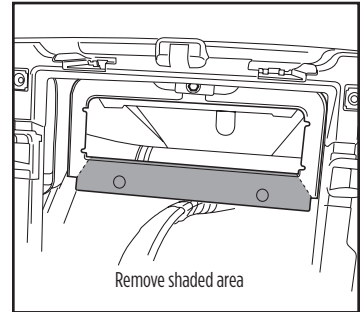

(Figure D)

KIT ASSEMBLY

Note: For proper orientation, the locating tabs on the **radio housing** are more to the top of the kit than bottom. (Figure A)

1. Rotate the **brackets** into the **radio housing**. (Figure B)
2. Slide the radio into the bracket/radio housing assembly and secure using the screws supplied with the radio. (Figure C)
3. Locate the factory wiring harness and antenna plug in the dash. Metra recommends using the proper mating adapters from Metra and/or AXXESS.
4. Reassemble the dash in reverse order of disassembly.

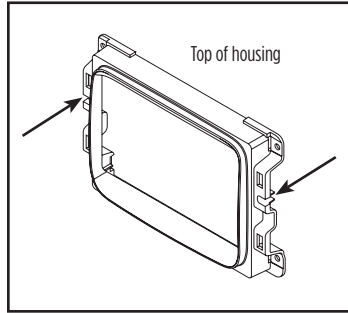

(Figure A)

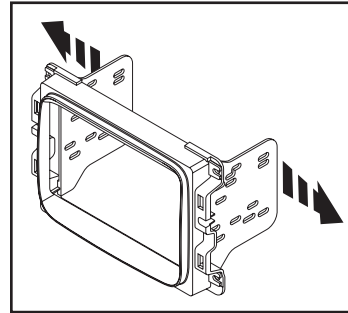

(Figure B)

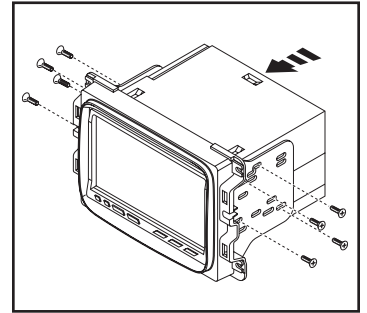

(Figure C)



95-6518B
INSTALLATION INSTRUCTIONS



Having difficulties? We're here to help.



Contact our Tech Support line at:

386-257-1187



Or via email at:

techsupport@metra-autosound.com

Tech Support Hours (Eastern Standard Time)

Monday - Friday: 9:00 AM - 7:00 PM

Saturday: 10:00 AM - 7:00 PM

Sunday: 10:00 AM - 4:00 PM



KNOWLEDGE IS POWER

Enhance your installation and fabrication skills by enrolling in the most recognized and respected mobile electronics school in our industry. Log onto www.installerinstitute.edu or call 386-672-5771 for more information and take steps toward a better tomorrow.



**Metra recommends MECP
certified technicians**



Chrysler 200 LX (con pantalla de 3.0") **2015 y mas**
Jeep Cherokee Sport **2014 y mas**
Ram Trucks (sin pantalla táctil de 8.4") **2013-2018**
Ram Classic Trucks (sin pantalla táctil de 8.4") **2019 y mas**

Visite MetraOnline.com para más información acerca del producto y las aplicaciones específicas más actualizadas del vehículo

CARACTERÍSTICAS DEL KIT

- Provisión de radio ISO DDIN
- Pintura negro mate
- **Nota:** Se requieren modificaciones a la cavidad del radiode fábrica

COMPONENTES DEL KIT

- A) Carcasa del radio • B) Soportes

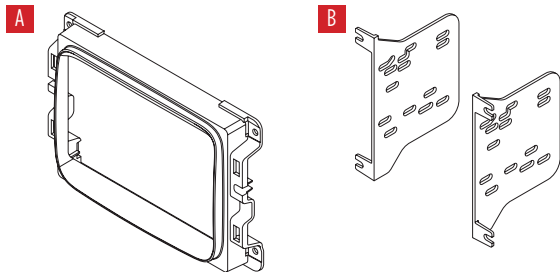

INDICE

Desmontaje del tablero	
-Chrysler 200 LX (con pantalla de 3.0") 2015 y mas	2
-Jeep Cherokee Sport 2014 y mas	3-4
-Ram Trucks (sin pantalla táctil de 8.4") 2013-2018	5
-Ram Classic Trucks (sin pantalla táctil de 8.4") 2019 y mas	5
Ensamble del kit	6

CABLEADO Y CONEXIONES DE ANTENA (se vende por separado)

- Arnés de cableado: Visite metraonline.com para conocer las opciones de interfaz de control de audio/video y volante.
- Adaptador de antena: 40-EU55

HERRAMIENTAS NECESARIAS

- Herramienta para remoción de paneles
- Destornillador Phillips • Llave de tubo de 9/32"

¡Atención! Deje que el vehículo se asiente con la llave fuera del encendido durante unos minutos antes de quitar la radio de fábrica. Al probar el equipo del mercado de accesorios, asegúrese de que todo el equipo de fábrica esté conectado antes de encender el llave de encendido.

DESMONTAJE DEL TABLERO

Chrysler 200 LX (con pantalla de 3.0")
2015 y mas

1. Desenganche el bisel de la moldura del radio del vehículo. (Figura A)
2. Retire los (4) tornillos que sujetan el radio a tablero, desconecte los conectores unidos y luego quite el radio.

Continúe con el ensamble del kit

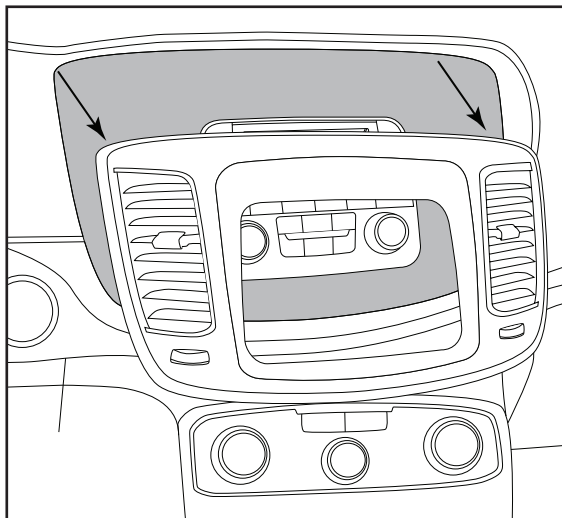

(Figura A)

DESMONTAJE DEL TABLERO

Jeep Cherokee Sport 2014 y mas

1. Desenganche y quite el panel del control del clima del vehículo y póngalo a un lado. (Figura A)
2. Quite los (2) tornillos que sujetan el bisel de la moldura del radio al tablero. (Figura B)
3. Desenganche el bisel de la moldura del radio del vehículo. (Figura C)
4. Retire los (4) tornillos que sujetan el radio a tablero, desconecte los conectores unidos y luego quite el radio.

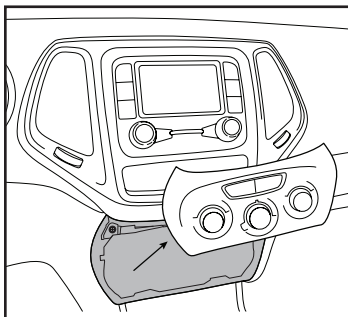

(Figura A)

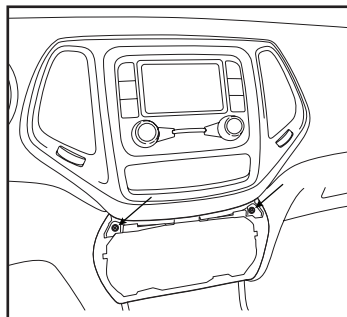

(Figura B)

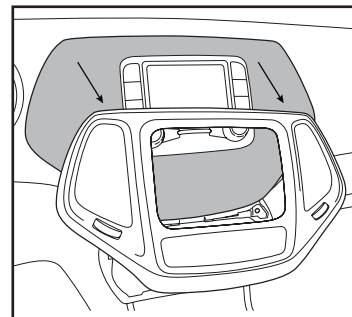

(Figura C)

Continúa en la página siguiente

DESMONTAJE DEL TABLERO (CONT.)

Jeep Cherokee Sport 2014-Up

Modificación al sub tablero:

1. Quite la cubierta de goma de la parte interior de la cavidad arriba del tablero, luego retire (1) tornillo que queda expuesto.
2. Quite (2) tornillos debajo de la cavidad del radio. (Figura A)
3. Desde el interior de la cavidad del radio, quite los (2) tornillos que sujetan el soporte metálico en el sub tablero y luego deséchelo. (Figura B)
4. Con cuidado, corte el plástico desde la porción inferior trasera de la cavidad del radio, hasta el soporte metálico. (Figura C)

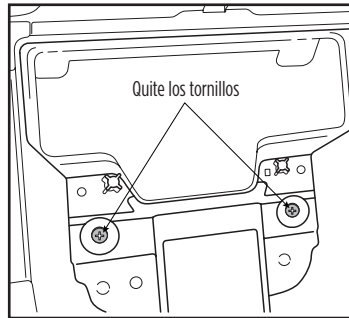

(Figura A)

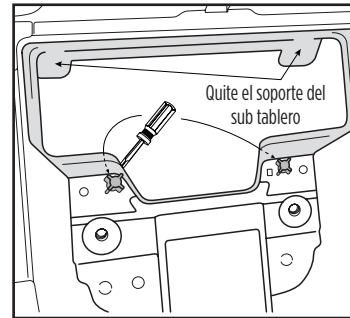

(Figura B)

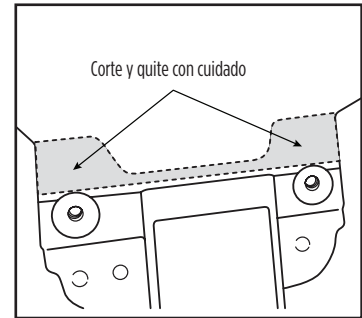

(Figura C)

Continúe con el ensamble del kit

DESMONTAJE DEL TABLERO

Ram Trucks (sin pantalla táctil de 8.4")
2013-2018

Ram Classic Trucks (sin pantalla táctil de 8.4")
2019 y mas

1. Quite el forro interior de la charola en la parte superior central del tablero y quite los (2) tornillos torx. (Figura A)
2. Suelte a presión y quite el panel del radio. (Figura B)

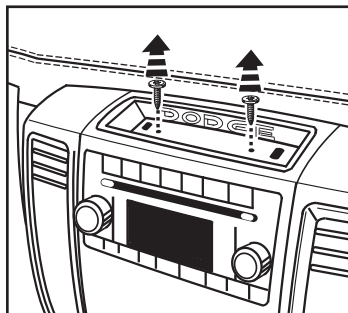

(Figura A)

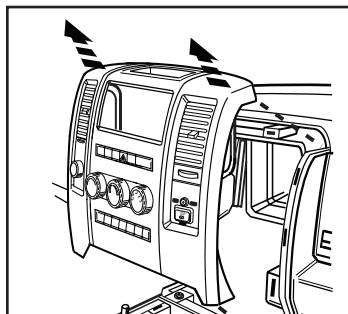

(Figura B)

3. Quite los cuatro tornillos y quite el radio. (Figura C)
4. El soporte trasero de fábrica deberá cortarse o quitarse para hacer espacio para un nuevo radio. La sección inferior puede quitarse con dos cortes en las esquinas inferiores. (Figura D)

Continúe con el ensamble del kit

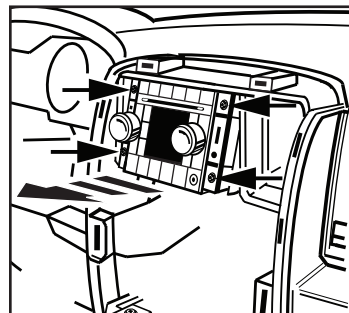

(Figura C)

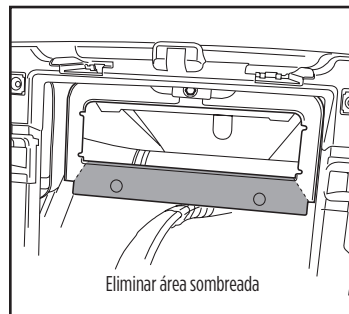

Eliminar área sombreada

(Figura D)

ENSAMBLE DEL KIT

Nota: Para una correcta orientación, las pestañas localizadoras de la **carcasa del radio** están más cerca de la parte superior del kit que de la parte inferior. (Figura A)

1. Gire los **soportes** hacia dentro de la **carcasa del radio**. (Figura B)
2. Deslice el radio dentro del conjunto del soporte/el radio y sujételo con los tornillos suministrados con el radio. (Figura C)
3. Localice el arnés de cableado de fábrica y el conector de la antena en el tablero. Metra recomienda el uso de los adaptadores adecuados de acoplamiento de Metra y/o AXCESS.
4. Vuelva a armar el tablero al revés de como lo desarmó..

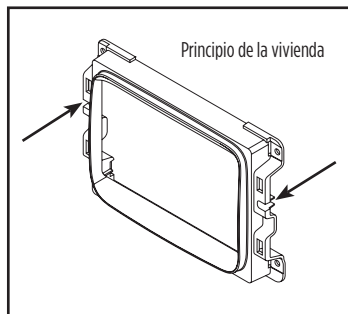

(Figura A)

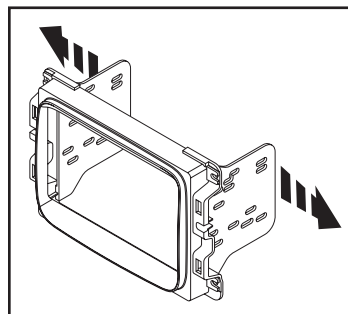

(Figura B)

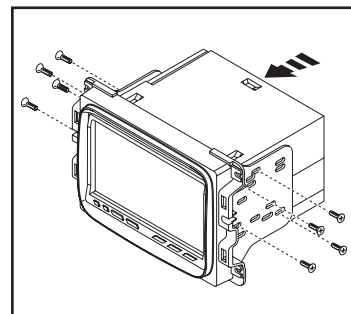

(Figura C)



95-6518B
INSTRUCCIONES DE INSTALACIÓN



¿Tienes dificultades? Estamos aquí para ayudar.



Póngase en contacto con nuestra
línea de soporte técnico en:
386-257-1187



O por correo electrónico a:
techsupport@metra-autosound.com

Horas de soporte técnico (hora estándar del este)

Monday - Friday: 9:00 AM - 7:00 PM

Saturday: 10:00 AM - 7:00 PM

Sunday: 10:00 AM - 4:00 PM



KNOWLEDGE IS POWER

Enhance your installation and fabrication skills by enrolling in the most recognized and respected mobile electronics school in our industry. Log onto www.installerinstitute.edu or call 386-672-5771 for more information and take steps toward a better tomorrow.



**Metra recomienda MECP
técnicos certificados**