



Ford F-250/350/450/550 XL (w/o color screen) 2017-up*

*Visit MetraOnline.com for up-to-date vehicle specific applications.

KIT FEATURES

- Designed specifically for the Pioneer DMH-C5500NEX 8-inch radio
- Painted scratch-resistant matte black to match the factory color and finish

KIT COMPONENTS

- A) Radio trim panel • B) Radio brackets • C) Switch housing • D) #8 x 3/8" Phillips screws (3) • E) #6 x 3/8" Phillips screws (4) • F) Panel clips (6)

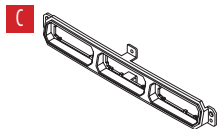
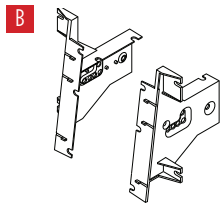
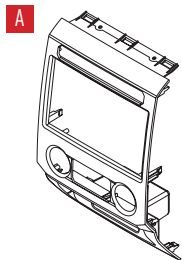

TABLE OF CONTENTS

Dash Disassembly	2
Kit Preparation	2
Kit Assembly	3

WIRING & ANTENNA CONNECTIONS (sold separately)

Wiring Harness: XSVI-5524-NAV

Antenna Adapter: 40-EU10

Steering wheel control interface: ASWC-1

TOOLS REQUIRED

- Panel removal tool • Phillips screwdriver
- 9/32" socket wrench • Torx screwdriver

Attention! Let the vehicle sit with the key out of the ignition for a few minutes before removing the factory radio. When testing the aftermarket equipment, ensure that all factory equipment is connected before cycling the key to ignition.

DASH DISASSEMBLY

1. Remove the storage mat in the pocket above the climate-control/radio trim panel, then remove (2) 9/32" screws exposed. (Figure A)
2. Unclip and remove the pocket, then remove (2) 9/32" screws exposed. (Figure B)
3. Unclip, unplug, and remove the climate-control/radio trim panel.

Continue to Kit Preparation

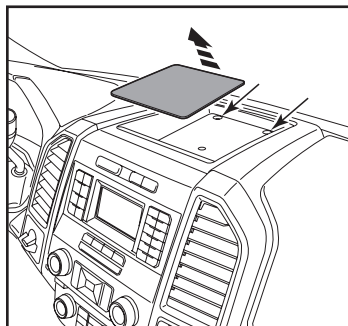

(Figure A)

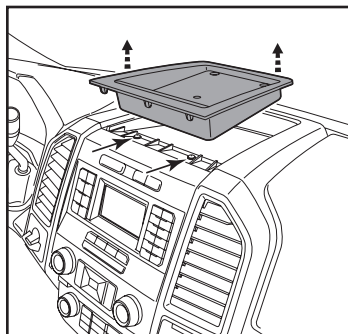

(Figure B)

KIT PREPARATION

From the factory climate-control/radio trim panel:

1. Remove (4) Torx screws securing the climate control panel, then remove. (Figure A)
2. Unclip and remove the switches. (Figure A)
3. Unclip and remove the LINE IN jack. (Figure A)
4. Unclip and remove the power port assembly. (Figure A)

To the 108-FD7B climate-control/radio trim panel:

5. Secure the climate control panel to the panel using (4) #6 x 3/8" Phillips screws provided. (Figure B)
6. Trim the bottom tab from the **switch housing** (see inset). Secure the **switch housing** to the panel using (3) #8 x 3/8" Phillips pan-head screws provided. (Figure B)
7. Snap the factory switches into the switch housing. (Figure B)
8. Snap the LINE IN jack to the panel. (Figure B)
9. Snap the power port assembly to the panel. (Figure B)
10. Attach (6) **panel clips** to the panel.

Continue to Kit Assembly

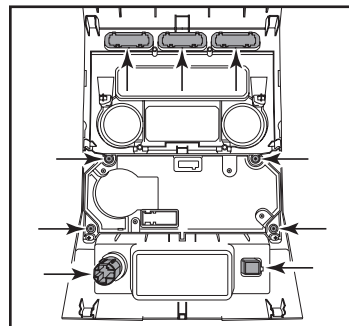

(Figure A)

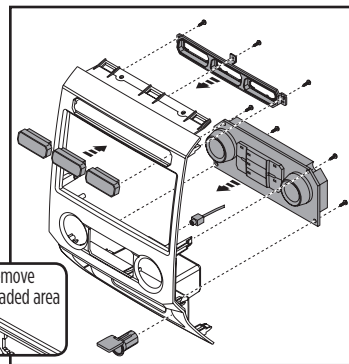

(Figure B)

KIT ASSEMBLY

Note: For steps 1 and 2, reference the installation manual provided with the radio for which hardware to use. The display screen and radio chassis use two different types of screws.

1. Secure the **radio brackets** to the radio chassis using (4) screws supplied with the radio. (Figure A)
2. Secure the radio display to the **radio brackets** using (4) screws supplied with the radio. (Figure B)
3. Locate the factory wiring harness and antenna connector in the dash, and complete all necessary connections to the radio. Metra recommends using the proper mating adapter from Metra and/or AXXESS. Test the radio for proper operation.

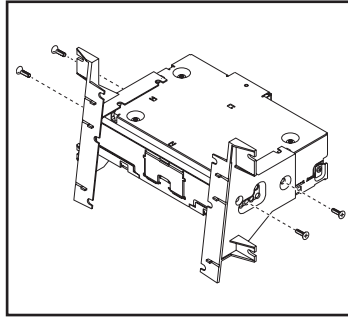

(Figure A)

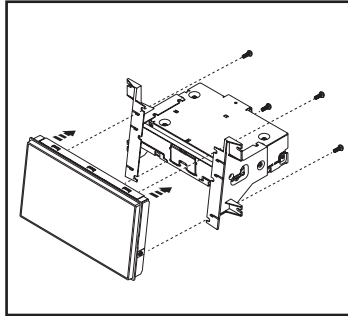

(Figure B)

4. Slightly unclip the middle ac vent panels in preparation for the next step.
5. Remove (4) screws in the dash cavity, then secure the completed assembly into the dash using those screws. (Figure C)
6. Clip the ac vent panels back in.
7. Snap the **radio trim panel** over the completed assembly, then reassemble the dash in reverse order of disassembly to complete the installation.

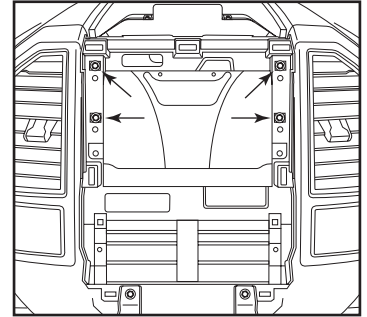

(Figure C)



108-FD7B

INSTALLATION INSTRUCTIONS



If you are having difficulties with the installation of this product, contact our Tech Support line either by phone at **386-257-1187**, or email at **techsupport@metra-autosound.com**. Before doing so, look over the instruction booklet a second time and ensure that the installation was performed exactly as the instruction booklet is stated. Have the vehicle apart and ready to perform troubleshooting steps before contacting Metra/Axxess Tech Support.



® KNOWLEDGE IS POWER

Enhance your installation and fabrication skills by enrolling in the most recognized and respected mobile electronics school in our industry. Log onto www.installerinstitute.com or call 800-354-6782 for more information and take steps toward a better tomorrow.



Metra recommends MECP certified technicians