



Honda HR-V 2016-2022

Visit MetraOnline.com for more detailed information about the product and up-to-date vehicle specific applications

KIT FEATURES

- ISO DIN radio provision with pocket
- Painted matte black

KIT COMPONENTS

- A) Radio trim panel • B) Radio trim panel brackets • C) Rear support bracket • D) Pocket • E) (4) #8 x 3/8" Phillips screws • F) (8) #6 x 3/8" Phillips screws

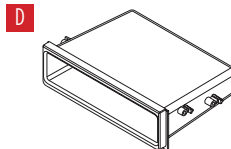
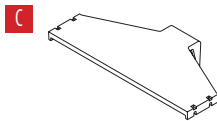
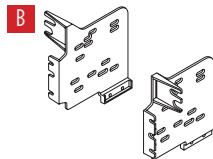
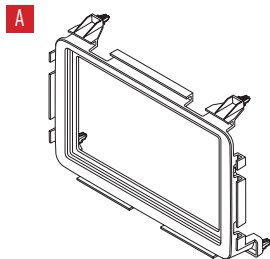

TABLE OF CONTENTS

Dash Disassembly	2
Kit Assembly	3

WIRING & ANTENNA CONNECTIONS (sold separately)

Wiring Harness: 70-1729

Antenna Adapter: 40-HD11

TOOLS REQUIRED

- Panel removal tool
- Phillips screwdriver
- 8 mm socket wrench

Attention! With the key out of the ignition, disconnect the negative battery terminal before installing this product. Ensure that all installation connections are secure before cycling the ignition to test this product.

DASH DISASSEMBLY

1. Open the glove box door.
2. Unclip and remove the trim panel surrounding the radio and a/c vent located to the left of the radio. (Figure A)
3. Remove (2) Phillips screws and (1) 8mm screw securing the factory radio, and then unplug and remove the radio. (Figure B)

Continue to kit assembly

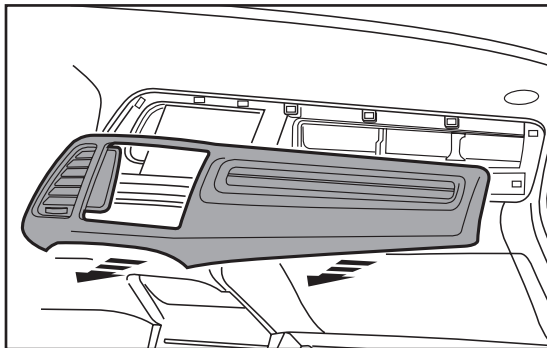

(Figure A)

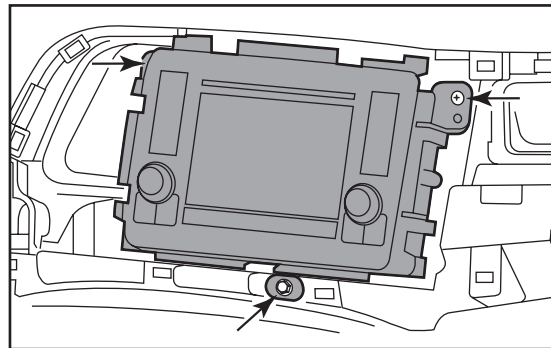

(Figure B)

KIT ASSEMBLY

1. Attach the **radio brackets** to the **radio trim panel** using (4) #6 x 3/8" Phillips screws supplied. (Figure A)
2. Attach the **rear support bracket** to the **radio brackets** using (4) #6 x 3/8" Phillips screws supplied. (Figure B)
3. Attach the **pocket** to the bracket/ panel using the (4) #8 x 3/8" Phillips screws supplied. (Figure C)
4. Remove the metal "DIN" sleeve and trim ring from the aftermarket radio.
5. Slide the radio into the completed assembly, and then secure it to the assembly using the screws supplied with the radio. (Figure D)

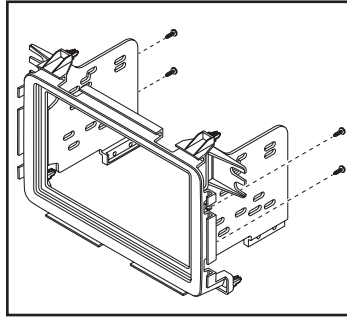

(Figure A)

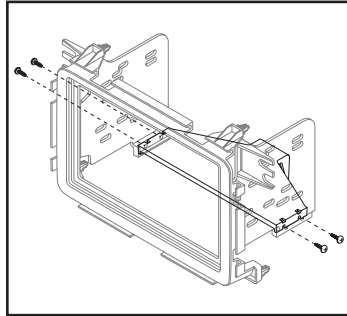

(Figure B)

6. Locate the factory wiring harness and antenna connector in the dash, and complete all necessary connections to the radio. Metra recommends using the proper mating adapter from Metra and/ or AXCESS. Re-connect the negative battery terminal and test the radio for proper operation.
7. Reassemble the dash in reverse order of disassembly.

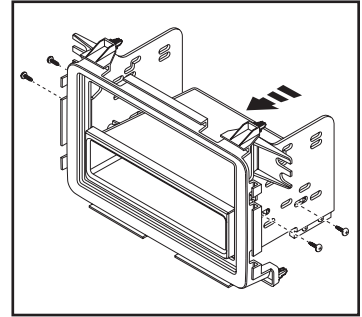

(Figure C)

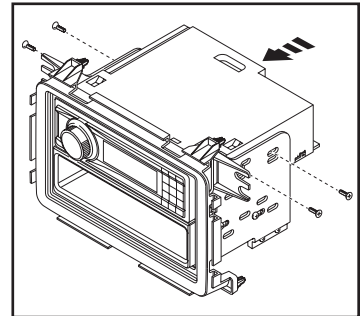

(Figure D)



99-7810B
INSTALLATION INSTRUCTIONS



Having difficulties? We're here to help.



Contact our Tech Support line at:

386-257-1187



Or via email at:

techsupport@metra-autosound.com

Tech Support Hours (Eastern Standard Time)

Monday - Friday: 9:00 AM - 7:00 PM

Saturday: 10:00 AM - 7:00 PM

Sunday: 10:00 AM - 4:00 PM



KNOWLEDGE IS POWER

Enhance your installation and fabrication skills by enrolling in the most recognized and respected mobile electronics school in our industry. Log onto www.installerinstitute.edu or call 386-672-5771 for more information and take steps toward a better tomorrow.



**Metra recommends MECP
certified technicians**



Honda HR-V 2016-2022

Visite MetraOnline.com para más información acerca del producto y las aplicaciones específicas más actualizadas del vehículo

CARACTERÍSTICAS DEL KIT

- Provisión de radio ISO DIN con cavidad
- Pintura negro matte

COMPONENTES DEL KIT

- A) Panel de la moldura del radio • B) Soportes del panel de la moldura del radio • C) Cavidad • D) Soporte de apoyo trasero
- E) (4) tornillos Phillips #8 x 3/8" • F) (8) tornillos Phillips #6 x 3/8"

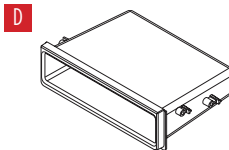
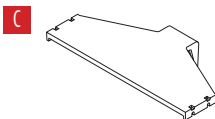
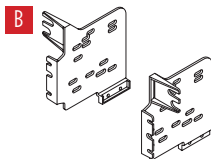
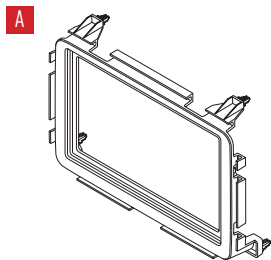

INDICE

Desmontaje del tablero	2
Ensamble del kit	3

CABLEADO Y CONEXIONES DE ANTENA

(se venden por separado)

Arnés de cableado: 70-1729

Adaptador de antena: 40-HD11

HERRAMIENTAS NECESARIAS

- Herramienta para remoción de paneles
- Destornillador Phillips • Llave de tubo de 8 mm

¡Atención! Con la llave fuera del encendido, desconecte el terminal negativo de la batería antes de instalar este producto. Asegúrese de que todas las conexiones de la instalación estén seguras antes de encender y apagar el encendido para probar este producto.

DESMONTAJE DEL TABLERO

1. Abra la puerta de la guantera.
2. Desenganche y quite todo el panel de la moldura que rodea el radio de fábrica incluyendo las rejillas del aire acondicionado a la izquierda del radio y arriba de la guantera. (Figura A)
3. Quite los (2) tornillos Phillips y el (1) perno de 8 mm que sujetan el radio de fábrica, luego desconecte y quite el radio. (Figura B)

Continúe ensamble del kit

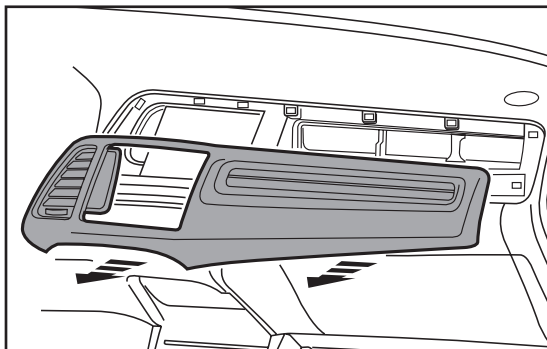

(Figura A)

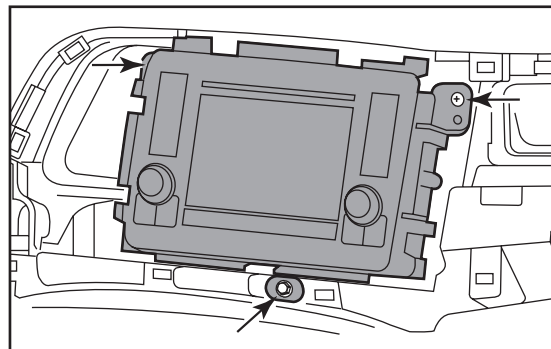

(Figura B)

ENSAMBLE DEL KIT

1. Una los **soportes del radio** al **panel de la moldura del radio** con los (4) tornillos Phillips #6 x 3/8" suministrados. (Figura A)
2. Una el soporte de **apoyo trasero** a los **soportes del radio** con los (4) tornillos Phillips #6 x 3/8" suministrados. (Figura B)
3. Una la **cavidad** al ensamble del soporte con los (4) tornillos Phillips #8 x 3/8" suministrados. (Figura C)
4. Quite la manga de metal "DIN" y el anillo de la moldura del radio de mercado secundario.
5. Deslice el radio en el ensamble terminado y luego sujételo al ensamble con los tornillos suministrados con el radio. (Figura D)

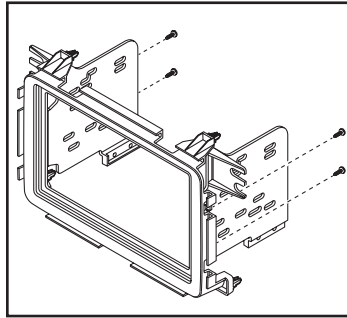

(Figura A)

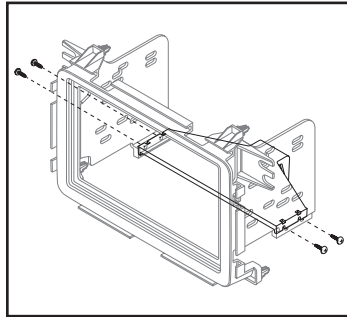

(Figura B)

6. Localice el arnés de cableado de fábrica y el conector de la antena en el tablero y realice todas las conexiones necesarias al radio. Metra recomienda el uso de adaptadores adecuados de acoplamiento de Metra y/o de AXXESS. Vuelva a conectar la terminal negativa de la batería y pruebe el radio para verificar que funcione correctamente.
7. Vuelva a armar el tablero al revés de como lo desarmó.

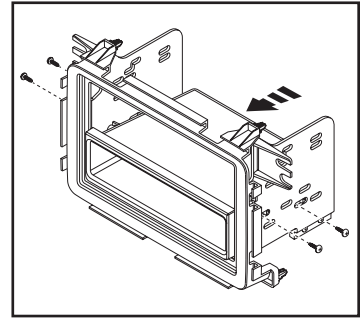

(Figura C)

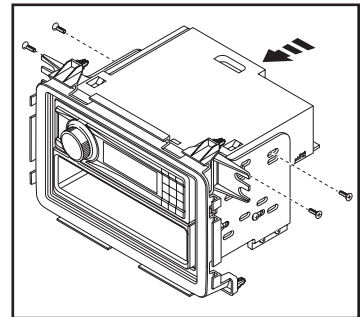

(Figura D)



99-7810B
INSTRUCCIONES DE INSTALACIÓN



¿Tienes dificultades? Estamos aquí para ayudar.



Póngase en contacto con nuestra
línea de soporte técnico en:
386-257-1187



O por correo electrónico a:
techsupport@metra-autosound.com

Horas de soporte técnico (hora estándar del este)

Monday - Friday: 9:00 AM - 7:00 PM

Saturday: 10:00 AM - 7:00 PM

Sunday: 10:00 AM - 4:00 PM



KNOWLEDGE IS POWER

Enhance your installation and fabrication skills by enrolling in the most recognized and respected mobile electronics school in our industry. Log onto www.installerinstitute.edu or call 386-672-5771 for more information and take steps toward a better tomorrow.



**Metra recomienda MECP
técnicos certificados**