



Installation instructions for part 95-9311B

BMW 3-Series 1999-2005, 3-Series (coupe, convertible) 2006, M3 2001-2006 (for factory switch panel with one long opening) 95-9311B

KIT FEATURES

- ISO DDIN radio provision
- *Painted matte black*
- *Relocates factory climate control and switches*



KIT COMPONENTS

- A) Radio trim panel • B) Back up housing • C) Radio brackets • D) Climate and switch panel housing
- E) Climate bracket • F) (4) #8 x 1/2" Phillips screws • G) (2) #8 x 3/8" Phillips screws • H) (2) panel clips

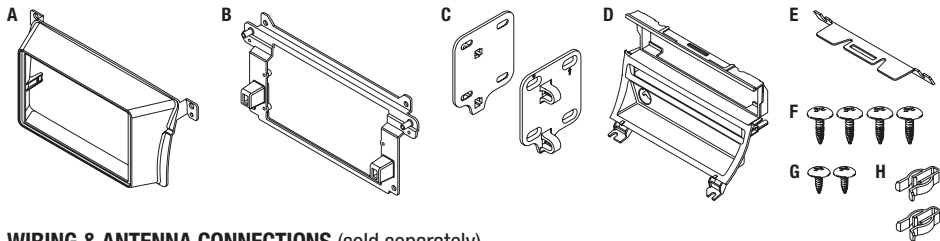

WIRING & ANTENNA CONNECTIONS (sold separately)

Wiring Harness: • 70-8590 • 70-9003 (nav models 02-06) Antenna Adapter: • 40-VW10 40-EU10 (nav models 02-06)

Table of Contents

Dash Disassembly	2-4
Kit Assembly	5
Climate and Switch Panel Assembly	6

TOOLS REQUIRED

- Panel removal tool • Phillips screwdriver
- Pick tool

CAUTION! All accessories, switches, climate controls panels, and especially air bag indicator lights must be connected before cycling the ignition. Also, do not remove the factory radio with the key in the on position, or while the vehicle is running.

REV. 4/6/2016 INST95-9311B

Dash Disassembly

1. Unclip and remove the trim panel above the glove box. (Figure A)
2. Unclip and remove the trim panel above the factory radio. (Figure B)
3. Remove (2) Phillips screws securing the radio and then unplug and remove the radio. (Figure C)

Continued on the next page

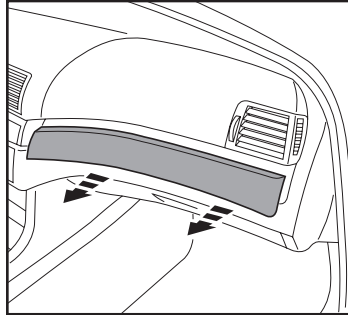

(Figure A)

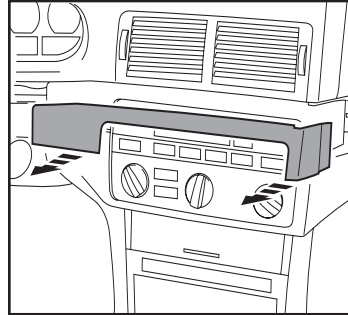

(Figure B)

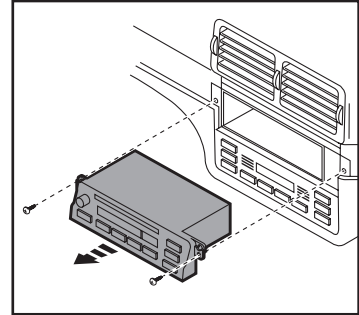

(Figure C)

Dash Disassembly

4. Unsnap and remove the climate control panel. (Figure D)
5. Pull straight up on the shift knob to remove. (Figure E)
6. Unclip and remove the boot around the shift selector. (Figure F)

Continued on next page

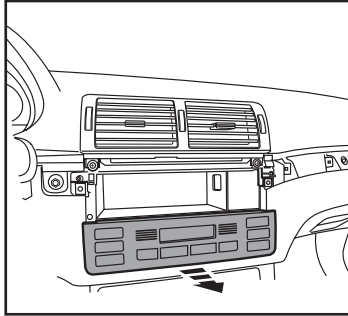

(Figure D)

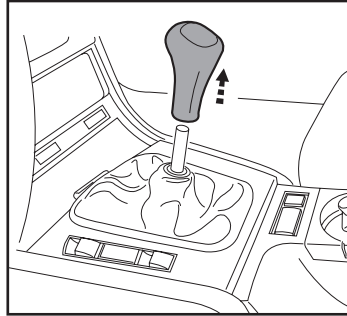

(Figure E)

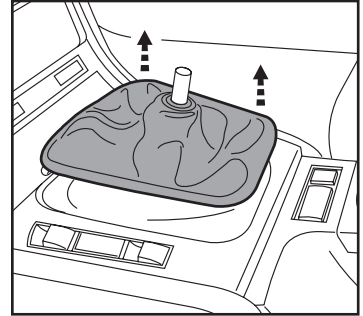

(Figure F)

Dash Disassembly

7. Remove (2) Phillips screws securing the shift selector trim panel, and then unclip and remove the panel. (Figure G)
8. Open the upper door on the lower switch panel. Using a pick tool, or something suitable, disengage (2) clips in the upper corners of the tray to remove the tray and door. (Figure H)
9. Remove (4) Phillips screws now exposed securing the lower switch panel, and then unplug and remove the panel. (Figure I)

Note: All of the switches will need to be removed and installed into the new switch panel provided. (Figure I)

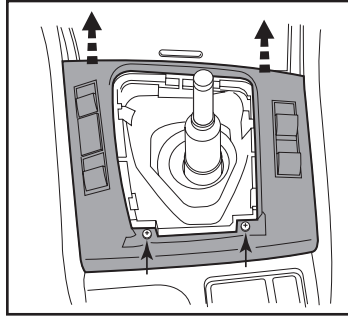

(Figure G)

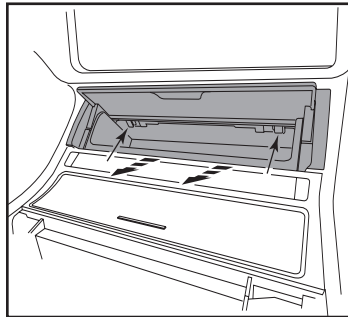

(Figure H)

10. Remove (2) Phillips screws, and then unclip and move aside the vent assembly above the radio opening. It is not necessary to remove the assembly. But if desired, there will be a cable attached to the assembly that will need to be removed. (Figure J)
11. *For non-NAV equipped cars,* remove (2) Phillips screws securing the plastic radio/climate housing from radio/climate cavity, and then remove.

Continue to kit assembly

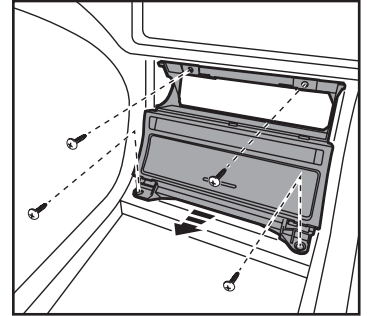

(Figure I)

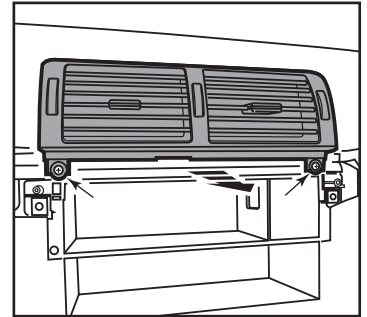

(Figure J)

Kit Assembly

1. Attach the *radio brackets* to the radio using the screws supplied with the radio. (Figure A)
2. Attach the *back-up housing* to the radio/bracket assembly with the (4) #8 x 1/2" Phillips screws supplied. (Figure B)
3. Locate the factory wiring harness and antenna connector in the dash, and complete all necessary connections to the radio and climate control panel. Metra recommends using the proper mating adapter from Metra and/or AXXESS. Re-connect the negative battery terminal and test the radio for proper operation.

Note: After all testing has been performed, disconnect the climate control panel, relocate the harness to the lower switch panel area, and then proceed to the next step.

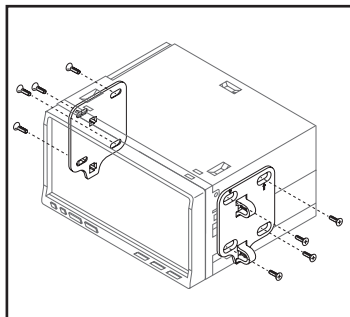

(Figure A)

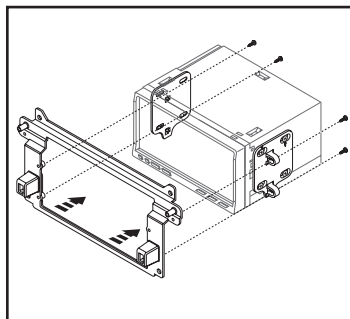

(Figure B)

4. Secure the completed assembly into the radio/climate cavity using the (2) #8 x 3/8 inch screws supplied.
5. Secure the vent assembly to the vehicle using the (2) factory Phillips screws removed in step 10 of dash disassembly.
6. Attach (2) *panel clips* provided with the kit onto the *radio trim panel* (Figure C), and then attach the panel to the radio assembly. Secure the assembly to the vehicle using the (2) factory Phillips screws removed in step 3 of dash disassembly.

Continue to climate and switch panel assembly

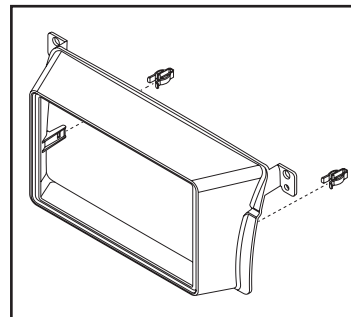

(Figure C)

Climate and switch panel assembly

1. Secure the *climate bracket* onto the top of the *climate and switch panel housing*. (Figure A)
2. Snap the climate control panel and all switches into the *climate and switch panel housing*. Connect all electrical connectors, and then secure the assembly into the lower dash opening with the (4) factory screws removed in step 9 of dash disassembly. (Figure B)
3. Reassemble the dash in reverse order of disassembly.

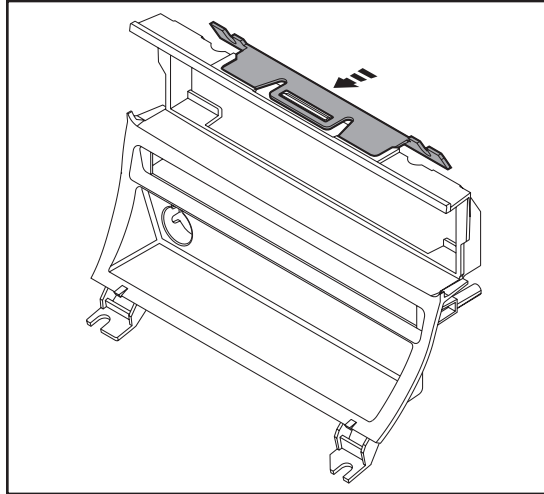

(Figure A)

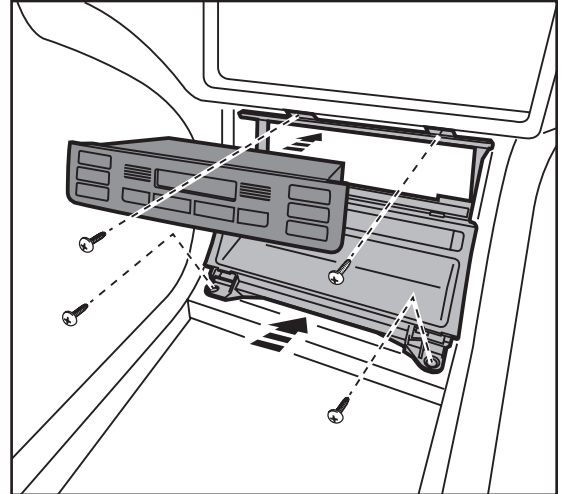

(Figure B)



95-9311B



Installation instructions for part 95-9311B



REV. 4/6/2016 INST95-9311B

IMPORTANT

If you are having difficulties with the installation of this product, please call our Tech Support line at 1-800-253-TECH. Before doing so, look over the instructions a second time, and make sure the installation was performed exactly as the instructions are stated. Please have the vehicle apart and ready to perform troubleshooting steps before calling.



KNOWLEDGE IS POWER

Enhance your installation and fabrication skills by enrolling in the most recognized and respected mobile electronics school in our industry. Log onto www.installerinstitute.com or call 800-354-6782 for more information and take steps toward a better tomorrow.



Metra recommends MECP certified technicians



INSTRUCCIONES DE INSTALACIÓN PARA LA PIEZA 95-9311B

BMW 3-Series 1999-2005, 3-Series (cupé, convertible) 2006, M3 2001-2006 (para panel de interruptores de fábrica con una apertura larga) 95-9311B

CARACTERÍSTICAS DEL KIT

- Provisión de radio ISO DDIN
- *Pintura negro de mate*

COMPONENTES DEL KIT

- A) Panel de la moldura del radio • B) Carcasa de respaldo • C) Soportes del radio • D) Carcasa del clima y panel de interruptores
- E) Soporte del clima • F) (4) tornillos Phillips #8 de 1/2" • G) (2) tornillos Phillips #8 de 3/8" • H) (2) ganchos para panel

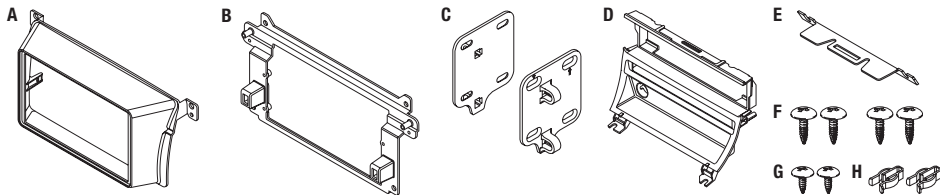

CABLEADO Y CONEXIONES DE ANTENA (se venden por separado)

Arnés de cables: • 70-8590 • 70-9003 (nav modelos 02-06) Adaptador de antena: • 40-VW10 40-EU10 (nav modelos 02-06)

Indice

Desmontaje del tablero	2-4
Ensamble del kit	5
Ensamble del panel de interruptores y del clima ...	6

TOOLS REQUIRED

- Herramienta para quitar paneles
- Destornillador Phillips • Herramienta en punta

¡PRECAUCIÓN! Todos los accesorios, interruptores, paneles de Controles de temperatura interior, y especialmente las luces indicadoras de bolsas de aire deben estar antes de un ciclo del encendido. Además, no se retire el radio de fábrica con la llave en la posición de encendido, o mientras el vehículo está en marcha.

REV. 4/6/2016 INST95-9311B

Desmontaje del tablero

1. Desenganche y quite el panel de la moldura que está sobre la guantera. (Figura A)
2. Desenganche y retire el panel de moldura que está arriba del radio de fábrica. (Figura B)
3. Quite los (2) tornillos Phillips que sujetan el radio, luego desconecte y quite el radio. (Figura C)

Continúa en la siguiente página

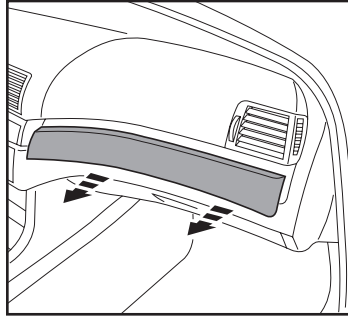

(Figura A)

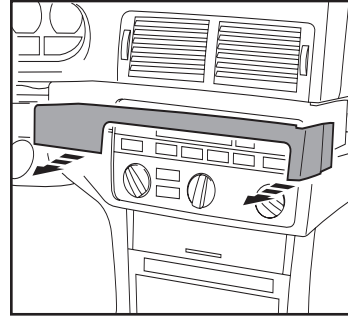

(Figura B)

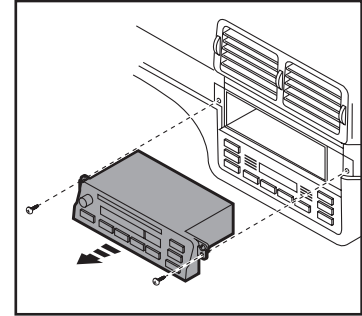

(Figura C)

Desmontaje del tablero

4. Desenganche y quite el panel del control de clima. (Figura D)
5. Jale directamente hacia arriba la perilla de la palanca de velocidades para quitarla. (Figura E)
6. Desenganche y quite la cubierta que rodea el selector de la palanca de velocidades. (Figura F)

Continúa en la siguiente página

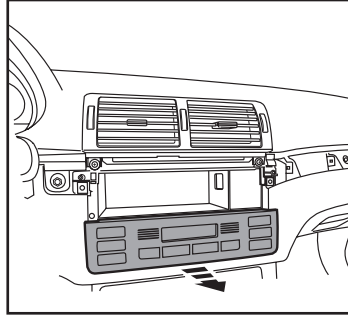

(Figura D)

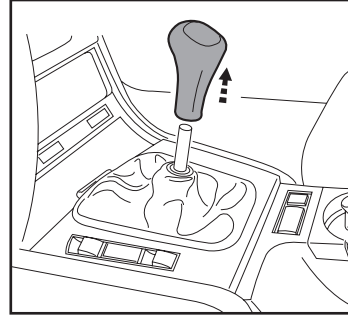

(Figura E)

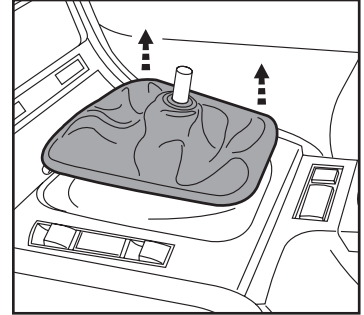

(Figura F)

Desmontaje del tablero

7. Quite los (2) tornillos Phillips que aseguran el panel de la moldura del selector de la palanca de velocidades y luego desenganche y quite el panel. (Figura G)
8. Abra la puerta superior en el panel de interruptores inferior. Con una herramienta en punta o algo adecuado, desenganche los (2) ganchos en las esquinas superiores de la bandeja para quitar la bandeja y la puerta. (Figura H)
9. Quite los (4) tornillos Phillips ahora expuestos que sujetan el panel de interruptores inferior, luego desconecte y quite el panel. (Figura I)

Nota: Todos los interruptores deberán quitarse e instalarse en el nuevo panel de interruptores suministrado. (Figura I)

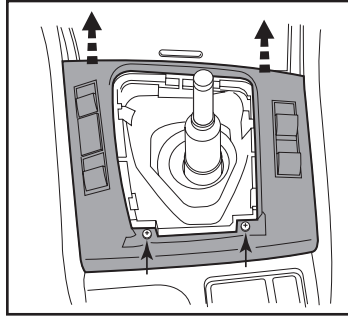

(Figura G)

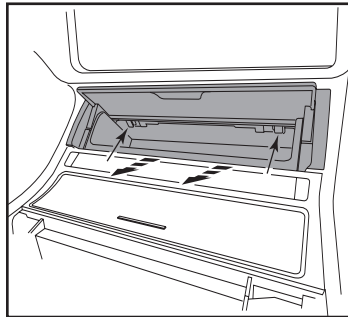

(Figura H)

10. Quite los (2) tornillos, luego desenganche y haga a un lado el ensamble de rejillas que está arriba de la apertura del radio. No es necesario quitar el ensamble. Pero si lo desea, habrá un cable conectado al ensamble que deberá quitar. (Figura J)
11. Para vehículos sin equipamiento de NAV, quite los (2) tornillos Phillips que sujetan la carcasa de plástico del clima/radio de la cavidad del clima/radio y luego quítela.

Continúe con el ensamble del kit

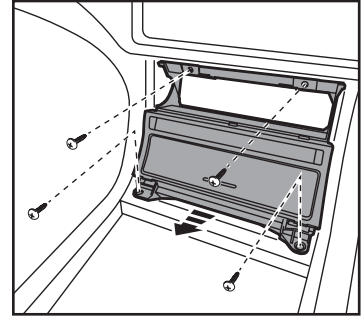

(Figura I)

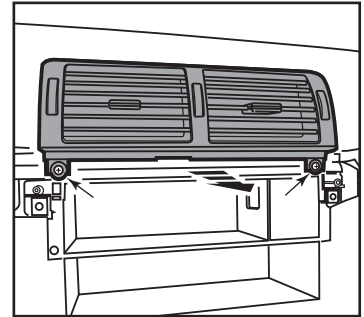

(Figura J)

Ensamble del kit

1. Una los *soportes del radio* al radio usando los tornillos que se suministraron con el radio. (Figura A)
2. Una la *carcasa de respaldo* al ensamble del soporte/radio con los (4) tornillos Phillips #8 x 1/2" suministrados. (Figura B)
3. Localice el arnés de cableado de fábrica y el conector de la antena en el tablero y realice todas las conexiones necesarias al panel del radio y control de clima. Metra recomienda el uso de adaptadores adecuados de acoplamiento de Metra y/o de AXCESS. Vuelva a conectar la terminal negativa de la batería y pruebe el radio para verificar que funcione correctamente.

Nota: Después de realizar todas las pruebas, desconecte el panel de control de clima, reubique el arnés al área inferior del panel de interruptores y luego continúe con el siguiente paso.

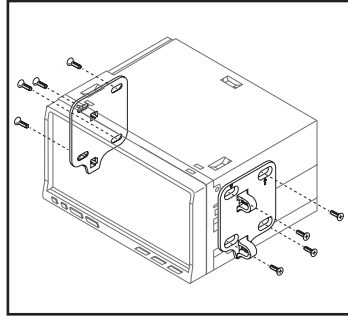

(Figura A)

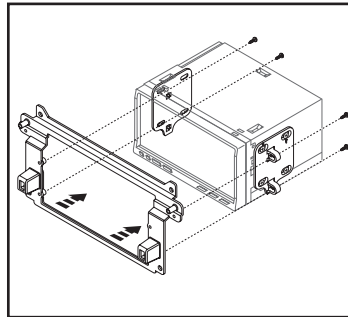

(Figura B)

4. Atornille el ensamble completo a la cavidad del radio/clima con los (2) tornillos #8 x 3/8" suministrados.
 5. Sujete el ensamble de rejillas al vehículo con los (2) tornillos Phillips de fábrica que quitó en el paso 10 del desensamble del tablero.
 6. Coloque los (2) *ganchos para panel* suministrados con el kit sobre el *panel de la moldura del radio* (Figura C) y luego una el panel al ensamble del radio. Sujete el ensamble al vehículo usando los (2) tornillos Phillips de fábrica que quitó en el paso 3 del desensamble del tablero.
- Continúe con el ensamble del panel de interruptores y del clima.*

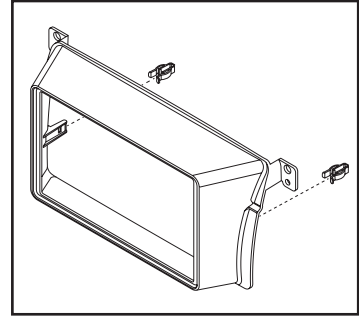

(Figura C)

Ensamble del panel de interruptores y del clima

1. Sujete el *soporte del clima* a la parte superior de la carcasa del clima y el panel de interruptores. (Figura A)
2. Coloque a presión el panel del control de clima y todos los interruptores en la *carcasa del clima y panel de interruptores*. Conecte todos los conectores eléctricos y luego sujete el ensamble a la apertura inferior del tablero con los (4) tornillos que quitó en el paso 9 del desensamble del tablero. (Figura B)
3. Vuelva a armar el tablero al revés de como lo desarmó.

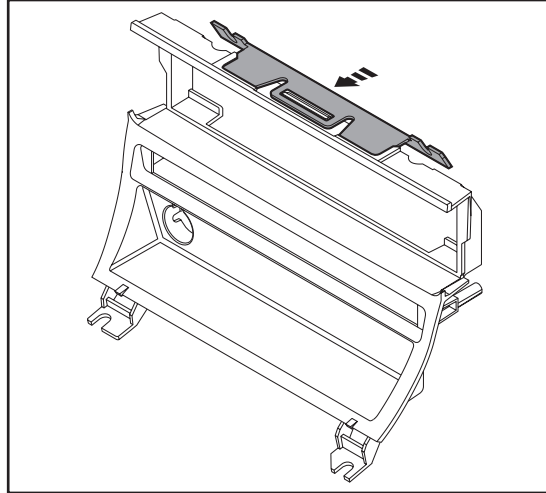

(Figura A)

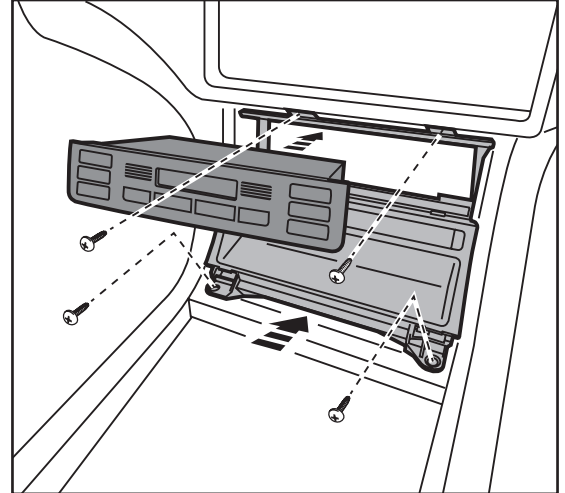

(Figura B)



95-9311B

A large central area of the page is filled with horizontal ruling lines, organized into two vertical columns. Each column contains 15 lines, providing a space for handwritten notes or calculations.



INSTRUCCIONES DE INSTALACIÓN PARA LA PIEZA 95-9311B



IMPORTANTE

Si tiene dificultades con la instalación de este producto, llame a nuestra línea de soporte técnico al 1-800-253-TECH. Antes de hacerlo, revise las instrucciones por segunda vez y asegúrese de que la instalación se haya realizado exactamente como se indica en las instrucciones. Por favor tenga el vehículo desarmado y listo para ejecutar los pasos de resolución de problemas antes de llamar.



EL CONOCIMIENTO ES PODER

Mejora sus habilidades de instalación y fabricación inscribiéndose en la escuela de dispositivos electrónicos móviles más reconocida y respetada de nuestra industria. Regístrese en www.installerinstitute.com o llame al 800-354-6782 para obtener más información y avance hacia un futuro mejor.



Metra recomienda técnicos con certificación del Programa de Certificación en Electrónica Móvil (Mobile Electronics Certification Program, MECP).