



INSTALLATION INSTRUCTIONS FOR PART 95-7417

APPLICATIONS

INFINITI 1996-1999 I-30
MERCURY 1993-2002 Villager
NISSAN 1995-1998 200SX/240SX
1998-2001 Altima / 1998-2004 Frontier
1995-2003 Maxima / 1996-2004 Pathfinder/QX4 1997-2000
1993-2003 Quest / 1995-1999 Sentra
2000-2004 Xterra

95-7417

KIT FEATURES

- DDIN Head Unit Provision
- Stacked ISO DIN Head Unit Provision

KIT COMPONENTS

A) DDIN Trim plate B) DDIN Brackets

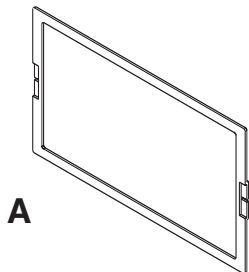

A

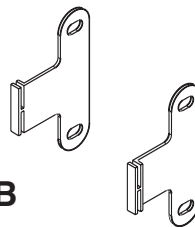

B

TOOLS REQUIRED:

Cutting Tool • Phillips Screwdriver • Socket Wrench

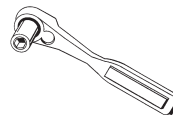
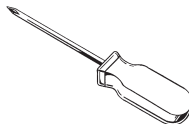
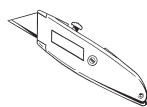

1-800-221-0932



www.metraonline.com

© COPYRIGHT 2004-2009 METRA ELECTRONICS CORPORATION

TABLE OF CONTENTS

Dash Disassembly

1996-1999 Infiniti I-30	1
1993-1995 Mercury Villager /1993-1995 Nissan Quest	2
1996-1998 Mercury Villager/ 1996-1998 Nissan Quest	3
1999-2002 Mercury Villager /1999-2003 Nissan Quest.....	4
1995-1999 Nissan Sentra /1995-1998 200 SX.....	5
1995-1998 Nissan 240 SX.....	6
1998-2001 Nissan Altima	7
1998-2001 Nissan Frontier/2000-2001 Nissan Xterra	8
2002-2004 Nissan Frontier/2002-2004 Nissan Xterra	9
1995-1999 Nissan Maxima.....	10
* 2000-2003 Nissan Maxima.....	11
1996-2000 Nissan Pathfinder/QX4 1997-2000.....	12
2001-2004 Nissan Pathfinder.....	13
* Fits all models EXCEPT the Bose and Comfort & Convenience pkgs.	

Kit Assembly

Double DIN Head Unit Provision.....	14
Stacked ISO DIN Head Unit Provision	15
Final Assembly	16



KNOWLEDGE IS POWER

Enhance your installation and fabrication skills by enrolling in the most recognized and respected mobile electronics school in our industry. Log onto www.installerinstitute.com or call 800-354-6782 for more information and take steps toward a better tomorrow.

CAUTION:

Do not cycle the key when removing a dash with passenger airbag ON/OFF switch.

1996-1999 INFINITI I-30

- 1** Disconnect the negative battery terminal to prevent an accidental short circuit.
- 2** Unclip and remove the shift lever trim panel and remove the (2) screws exposed.
- 3** Remove (1) screw to the left of the ashtray then unclip and remove the ashtray assembly.
- 4** Unclip and remove the clock/vent assembly.
- 5** Remove (4) screws securing the radio.

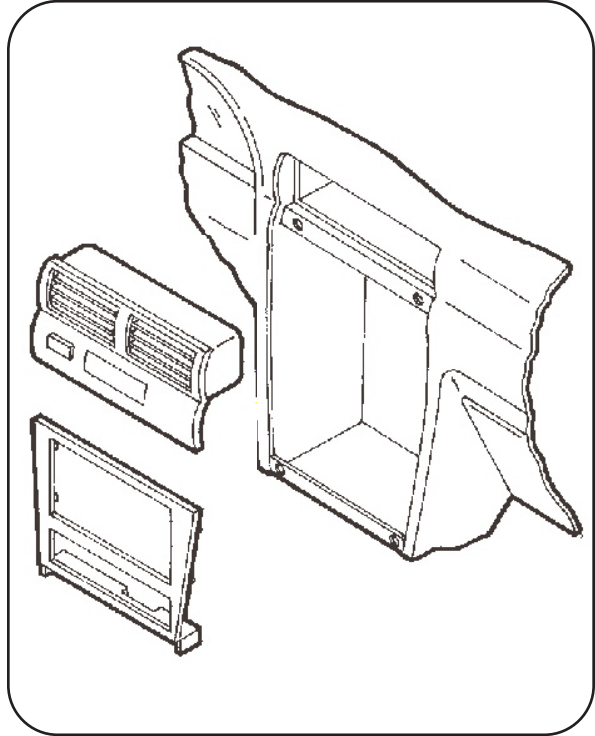

1993-1995 MERCURY VILLAGER
1993-1995 NISSAN QUEST

- 1** Disconnect the negative battery terminal to prevent an accidental short circuit.
- 2** Remove (1) screw above the climate controls.
- 3** Unclip and remove the radio trim panel.
- 4** Remove (4) screws securing the radio.

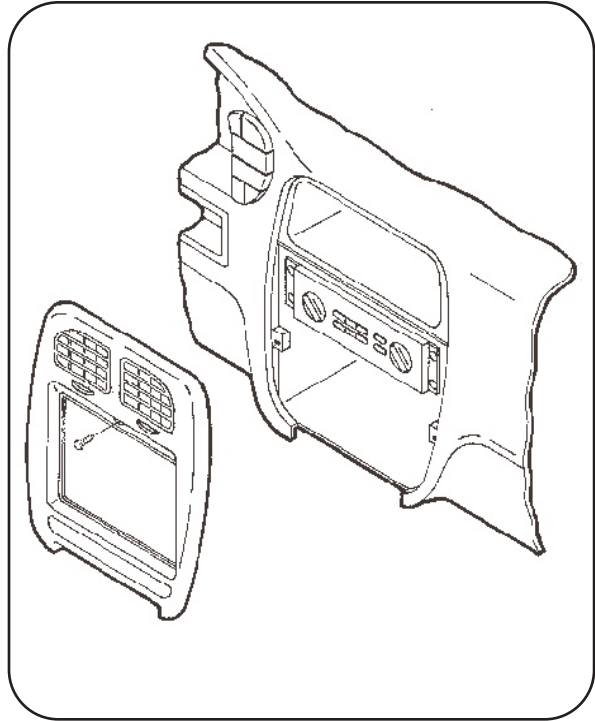

1996-1998 MERCURY VILLAGER
1996-1998 NISSAN QUEST

- 1** Disconnect the negative battery terminal to prevent an accidental short circuit.
- 2** Remove (4) plastic screws and screw anchors from the base of the storage compartment then remove the compartment.
- 3** Remove (2) Phillips screws from the base of the radio trim panel.
- 4** Remove (2) Phillips screws from above the radio opening.
- 5** Remove the ashtray.
- 6** Remove (4) screws securing the radio.

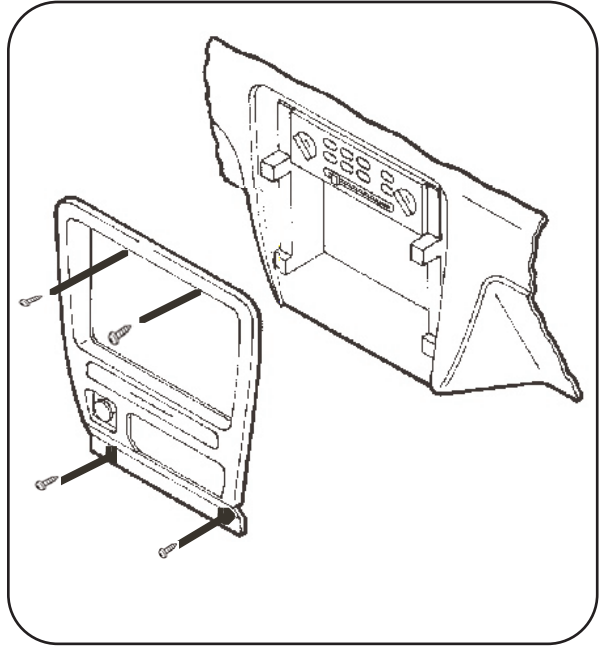

1999-2002 MERCURY VILLAGER
1999-2003 NISSAN QUEST

- 1** Disconnect the negative battery terminal to prevent an accidental short circuit.
- 2** Open the ashtray/cupholder assembly and depress the retaining clips on each side to remove.
- 3** Remove (2) Phillips screws from each side of the ashtray/cupholder.
- 4** Remove (4) plastic rivets from the lower pocket and slide the pocket back. Note: It is not necessary to fully remove the pocket.
- 5** Unclip the dash trim panel and remove.
- 6** Remove (4) Phillips screws securing the radio.

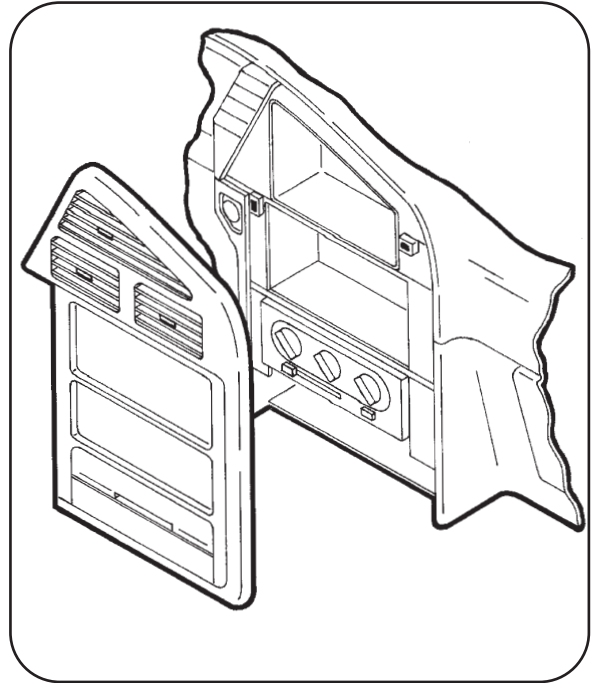

1995-1999 NISSAN SENTRA
1995-1998 200 SX

- 1** Disconnect the negative battery terminal to prevent an accidental short circuit.
- 2** Unclip and remove the dummy plate above the climate controls.
- 3** Remove (1) Phillips screw from behind dummy plate.
- 4** Unclip and remove radio trim panel.
- 5** Remove (4) Phillips screws securing radio.

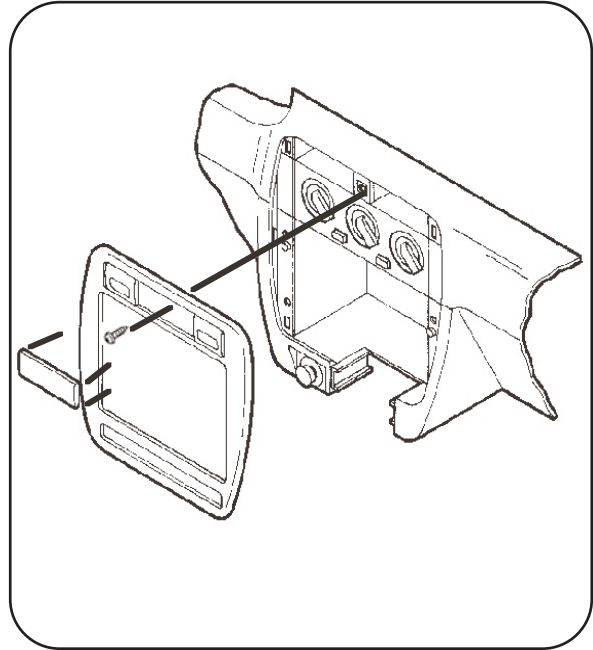

1995-1998 NISSAN 240 SX

- 1** Disconnect the negative battery terminal to prevent an accidental short circuit.
- 2** Unclip and remove the climate control trim panel and remove the (2) exposed behind.
- 3** Unclip and remove the shift lever trim panel and remove the (2) screws exposed behind.
- 4** Remove the ashtray and (1) Phillips screw exposed in the ashtray cavity.
- 5** Unclip and remove the radio trim panel, factory radio and pocket assembly.

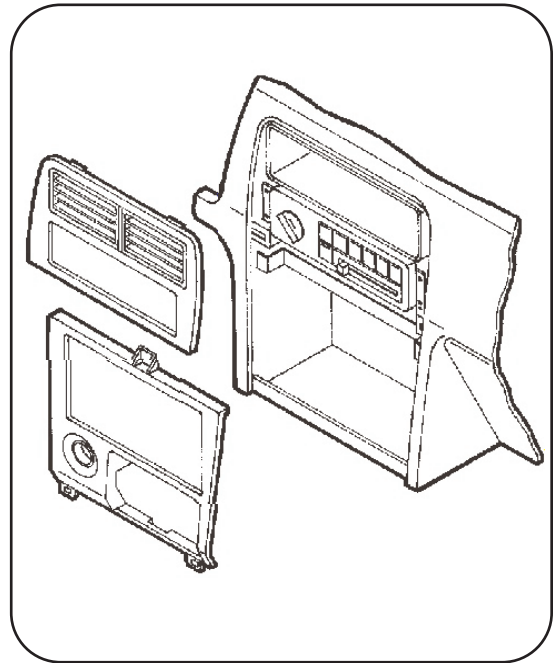

1998-2001 NISSAN ALTIMA

- 1** Disconnect the negative battery terminal to prevent an accidental short circuit.
- 2** Unclip the shift lever trim panel and remove (2) Phillips screws at the base of the radio trim panel.
- 3** Remove (2) Phillips screws above the radio opening.
- 4** Unclip and remove the radio trim panel.
- 5** Remove (4) Phillips screws securing the radio.

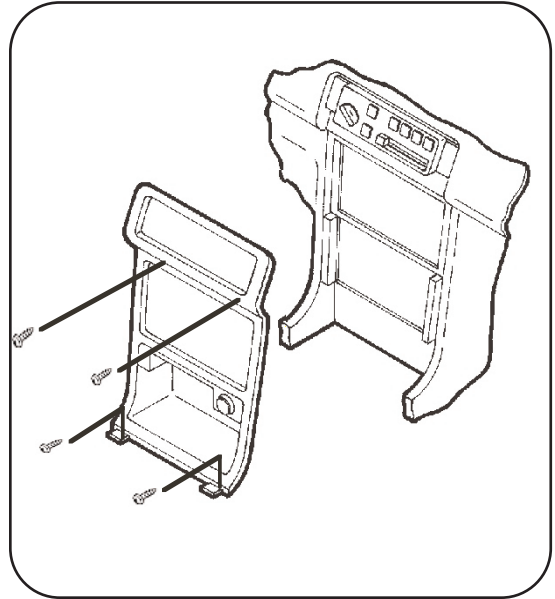

1998-2001 NISSAN FRONTIER
2000-2001 NISSAN XTERRA

- 1** Disconnect the negative battery terminal to prevent an accidental short circuit.
- 2** Remove the ashtray and the (2) Phillips screws exposed in the ashtray cavity.
- 3** Unclip and remove the radio trim panel.
- 4** Remove (4) Phillips screws securing the radio.

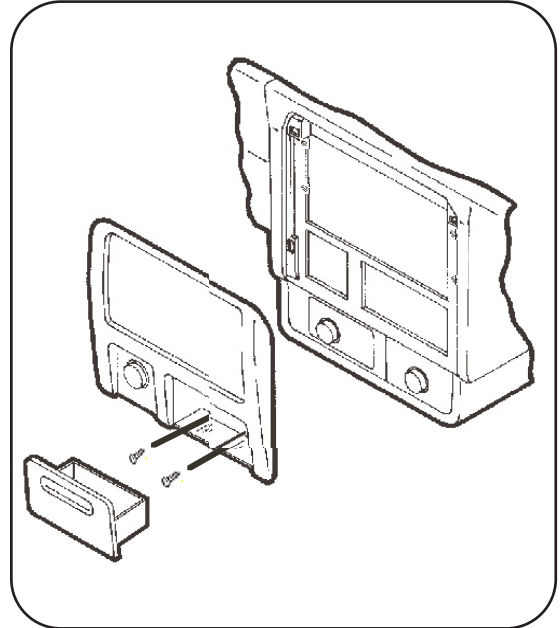

2002-2004 NISSAN FRONTIER
2002-2004 NISSAN XTERRA

- 1** Disconnect the negative battery terminal to prevent an accidental short circuit.
- 2** Unclip and remove the shift lever trim panel.
- 3** Remove (2) Phillips screws exposed in the shift lever cavity.
- 4** Remove (2) Phillips screws under the climate control.
- 5** Unclip and remove the radio trim panel.
- 6** Remove (4) Phillips screws securing the radio.

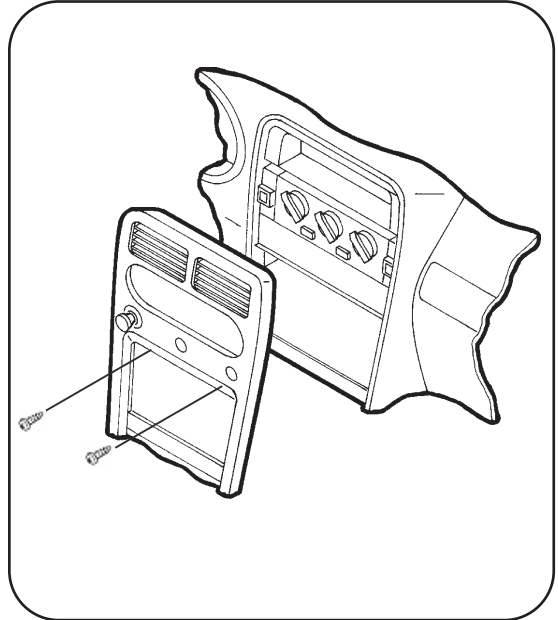

1995-1999 NISSAN MAXIMA

- 1** Disconnect the negative battery terminal to prevent an accidental short circuit.
- 2** Unclip the shift lever trim panel.
- 3** Remove the (2) Phillips screws at the base of the radio trim panel.
- 4** Remove (1) Phillips screw to the left of the ashtray and unclip the ashtray assembly.
- 5** Unclip and remove the clock/vent assembly.
- 6** Remove (4) Phillips screws securing the radio.

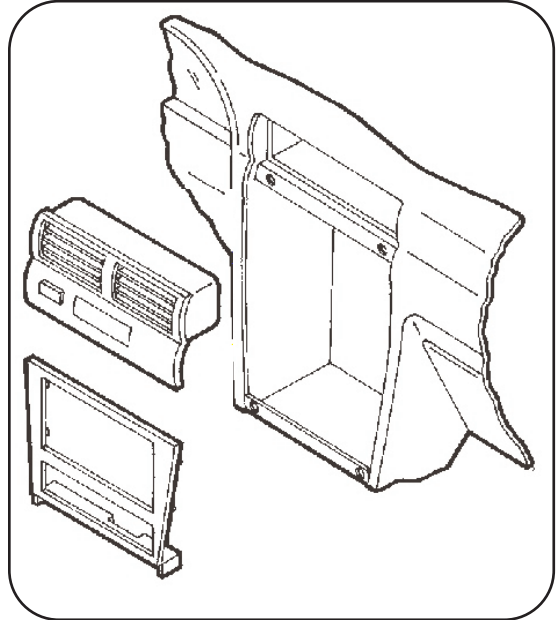

2000-2003 NISSAN MAXIMA

- 1 Disconnect the negative battery terminal to prevent an accidental short circuit.
- 2 Unclip and remove the vent/radio trim panel. **Note:** For Bose systems the vent assembly will be removed without the trim panel.
- 3 Remove the ashtray insert and (1) Phillips screw exposed behind.
- 4 Unclip and remove the shift lever/ash-tray trim panel.
- 5 Remove (2) Phillips screws above the radio and (2) Phillips screws below the climate control panel then remove the radio/climate control assembly.

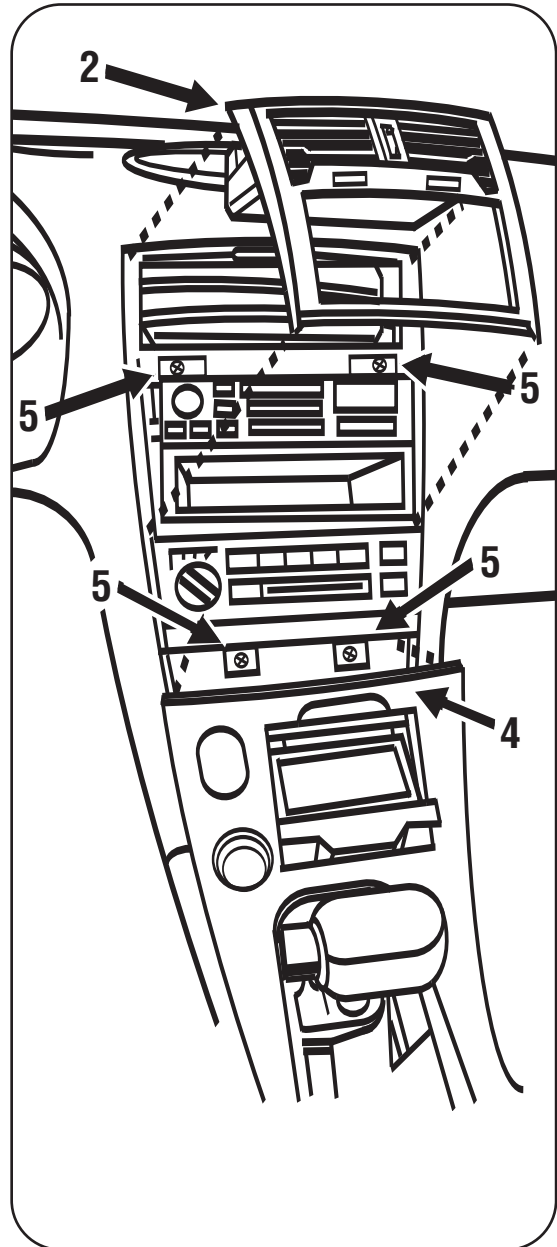

1996-2000 NISSAN PATHFINDER/QX4 1997-2000

- 1** Disconnect the negative battery terminal to prevent an accidental short circuit.
- 2** Remove (2) Phillips screws from the base of the radio trim panel.
- 3** Unclip and remove the radio trim panel.
- 4** Remove (4) Phillips screws securing radio.

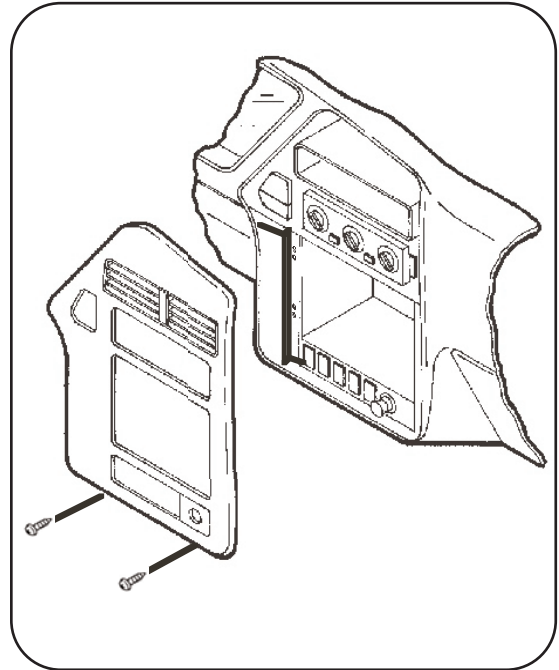

2001-2003 NISSAN PATHFINDER

- 1 Disconnect the negative battery terminal to prevent an accidental short circuit.
- 2 Unclip and remove the vent/clock assembly. (Figure A)
- 3 Remove (2) Phillips screws from the top of the radio trim panel then remove the panel. (Figure B)
- 4 Remove (4) Phillips screws securing radio. (Figure C)

A

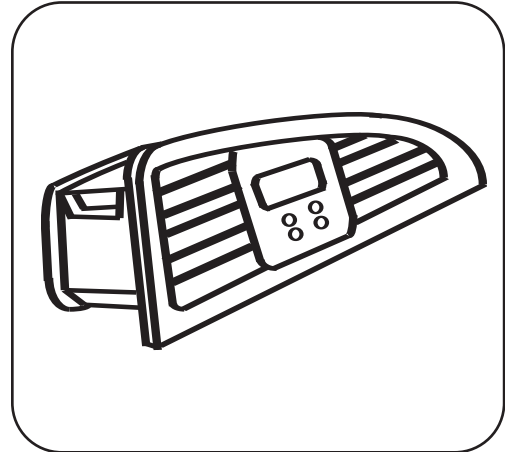

B

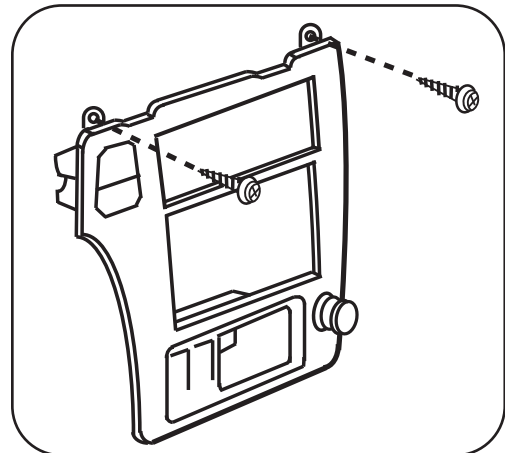

C

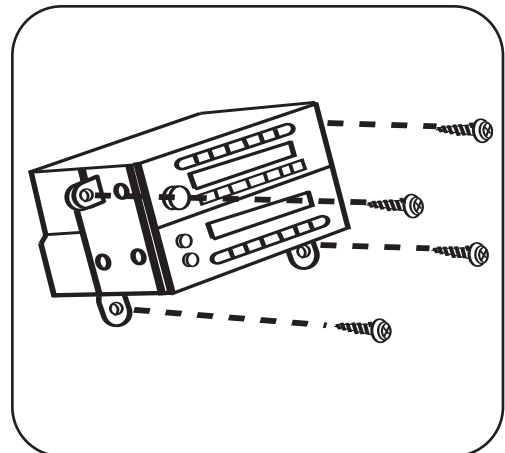

DOUBLE DIN HEAD UNIT PROVISION

- 1** Slide the appropriate bracket into the trim plate aligning the holes in the trim plate to the clips on the bracket. (Figure A)
- 2** Attach the factory mounting brackets and the 95-7417 DDIN trim plate/bracket assembly to the DDIN head unit with the screws supplied with the unit. (Figure B)

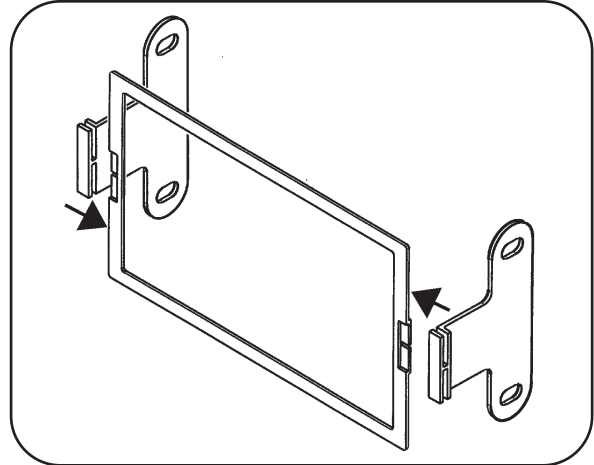
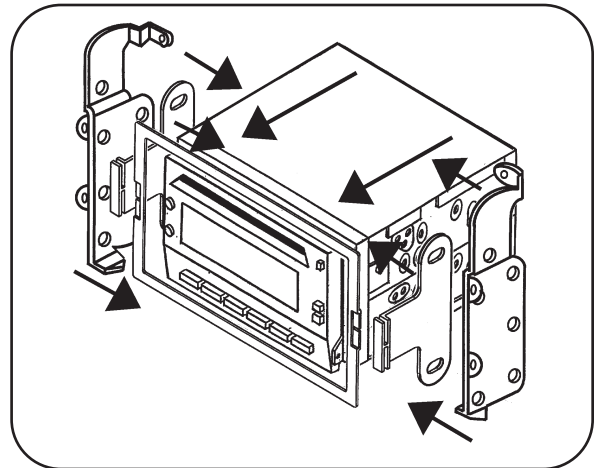
A

B

STACKED ISO DIN HEAD UNIT PROVISION

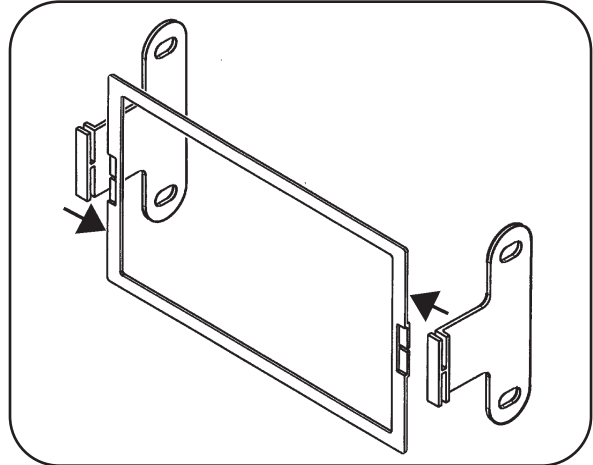
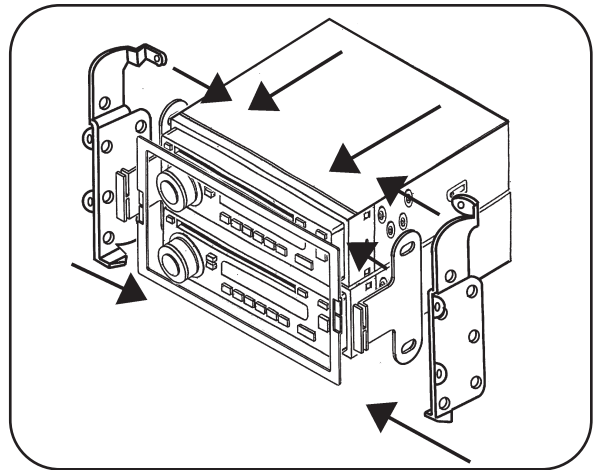
- 1 Slide the appropriate bracket into the trim plate aligning the holes in the trim plate to the clips on the bracket. (Figure A)
- 2 Attach the factory mounting brackets and the 95-7417 DDIN trim plate/bracket assembly to the stacked ISO DIN head units with the screws supplied with the units. (Figure B)

A**B**

FINAL ASSEMBLY

- 1 Locate the factory wiring harness in the dash and make the connection as shown. Metra recommends using the proper mating adapter and making the connections as shown. (Isolate and individually tape off the ends of any unused wires to prevent electrical short circuit.)
- 2 Re-connect the negative battery terminal and test the unit for proper operation.
- 3 Reassemble radio and dash assemblies in reverse order of disassembly.

FINAL WIRING CONNECTIONS

Make wiring connections using the EIA color code chart shown below and the instructions included with the head unit. Metra recommends making connections as shown below; Strip, Splice, Solder, Tape. Isolate and individually tape off ends of any unused wires to prevent electrical short circuit.

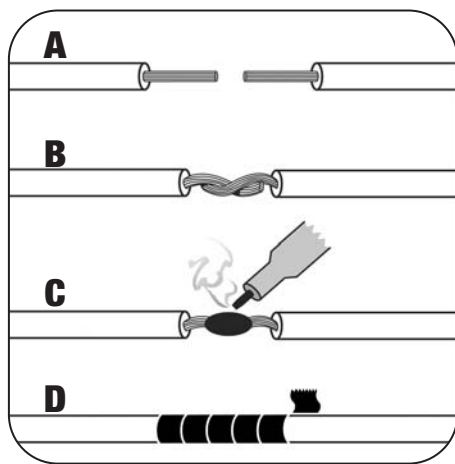

- A) Strip wire ends back 1/2"**
- B) Twist ends together**
- C) Solder**
- D) Tape**

METRA / EIA WIRING CODE

12V Ignition / Acc . . . Red	Right Front (+) Gray
12V Batt / Memory . . Yellow	Right Front (-) Gray / Black
Ground Black*	Left Front (+) White
Power Antenna Blue	Left Front (-) White / Black
Amp Turn-On Blue / White	Right Rear (+) Violet
Amp Ground Black / White	Right Rear (-) Violet / Black
Illumination Orange	Left Rear (+) Green
Dimmer Orange / White	Left Rear (-) Green / Black

***NOTE:** When Black a wire is not present, ground radio to vehicle chassis.
All colors may not be present on all leads due to manufacturer's specifications.

95-7417 INSTRUCTIONS

 **1-800-221-0932**  **www.metraonline.com**

REV. 07/28/09 © COPYRIGHT 2004-2009 METRA ELECTRONICS CORPORATION INST95-7417